

Kingdom of Saudi Arabia
Ministry of Health



National eHealth Strategy and Change Management Office
(SCMO)

Enabling Standards-Based eHealth Interoperability

IS0004

Saudi eHealth Core Interoperability Specification for
Coded Laboratory Orders

Version 1.0

February 22, 2015

Document Control Number: IS0004 Saudi eHealth Core IS for Coded Laboratory Orders

THIS PAGE INTENTIONALLY LEFT BLANK

TABLE OF CONTENTS

1. INTRODUCTION	6
1.1 DOCUMENT PURPOSE	6
1.2 DESCRIPTION	6
1.3 SCOPE	6
1.4 RELATIONSHIP BETWEEN LABORATORY ORDERS AND RESULTS REPORTS	7
1.5 METHODOLOGY	8
1.6 HOW TO READ THIS DOCUMENT	9
1.6.1 Where to Find Information	9
1.6.2 Related Documents	9
1.6.3 Document Conventions	11
2. USE CASE	12
2.1 USE CASE ACTORS AND SERVICES	12
2.2 DESIGN CONSTRAINTS AND ASSUMPTIONS	12
2.3 USE CASE FLOW OF EVENTS	13
2.3.1 Specific Workflow Scenarios	14
3. OVERVIEW OF WORKFLOWS	21
3.1 LABORATORY ORDER WORKFLOW.....	21
3.2 SPECIMEN WORKFLOW	25
3.3 USE OF KSA-WIDE IDENTIFIERS WITHIN CODED LABORATORY ORDERS.....	25
3.4 LABORATORY SUB-CONTRACTING WORKFLOW.....	26
4. CORE INTEROPERABILITY SPECIFICATION REQUIREMENTS	27
4.1 ACTOR MAPPING TO SAUDI EHEALTH IS SPECIFICATIONS	27
4.2 INTEROPERABILITY SEQUENCE DIAGRAMS	32
4.2.1 Main Flow Sequence Diagram.....	33
4.2.2 Cancel Order Sequence Diagram.....	39
4.2.3 Laboratory - Abort Order Sequence Diagram.....	42
5. CONFORMANCE REQUIREMENTS	46
5.1 LABORATORY ORDER CREATOR CONFORMANCE	46
5.2 LABORATORY ORDER FULFILLER CONFORMANCE	47
5.3 DOCUMENT REPOSITORY CONFORMANCE.....	49
6. SAUDI EHEALTH CONSTRAINTS ON THE SHARING OF LABORATORY INFORMATION	51
6.1 REQUIREMENTS FOR LABORATORY ORDER CREATOR	51
6.2 REQUIREMENTS FOR LABORATORY ORDER FULFILLER.....	53
6.3 REQUIREMENTS FOR DOCUMENT REPOSITORY.....	56
7. REFERENCED DOCUMENTS AND STANDARDS	57
8. APPENDIX B – EXAMPLE MESSAGES/DOCUMENTS	60

LIST OF TABLES

TABLE 2.1-1 USE CASE ACTORS.....	12
TABLE 2.1-2 USE CASE SERVICES	12
TABLE 3.1-1 LABORATORY ORDER STATUS ACTIONS BY THE ORDER PLACER	22
TABLE 3.1-2 LABORATORY ORDER STATUS ACTIONS BY THE LABORATORY.....	23
TABLE 4.1-1 INTEROPERABILITY CONFORMANCE REQUIREMENTS FOR LABORATORY ORDER CREATOR	28
TABLE 4.1-2 INTEROPERABILITY CONFORMANCE REQUIREMENTS FOR LABORATORY ORDER FULFILLER	29
TABLE 4.1-3 INTEROPERABILITY CONFORMANCE REQUIREMENTS FOR DOCUMENT REPOSITORY.....	31
TABLE 6-1 INTERNAL REFERENCES	57
TABLE 6-2 EXTERNAL REFERENCES.....	58

LIST OF FIGURES

FIGURE 1.4-1: OVERVIEW OF RELATIONSHIP BETWEEN SHARED CODED LAB RESULTS AND CODED LAB ORDERS INTEROPERABILITY SPECIFICATIONS	8
FIGURE 1.6.2-1 CODED LABORATORY ORDERS DOCUMENT ORGANIZATION	10
FIGURE 3.1-1: LABORATORY ORDER TRANSITION STATE DIAGRAM	22
FIGURE 4.2-1: CODED LABORATORY ORDERS SEQUENCE DIAGRAM (1).....	34
FIGURE 4.2-2 CODED LABORATORY ORDER SEQUENCE DIAGRAM (2).....	37
FIGURE 4.2-3 CODED LABORATORY ORDER SEQUENCE DIAGRAM (3).....	39
FIGURE 4.2-4 CANCELLED ORDER SEQUENCE DIAGRAM (1).....	40
FIGURE 4.2-5 CANCELLED ORDER SEQUENCE DIAGRAM (2).....	42
FIGURE 4.2-6 LABORATORY– ABORT ORDER (WITH NOTIFICATION) SEQUENCE DIAGRAM (1)	44
FIGURE 4.2-7 LABORATORY - ABORTED ORDER (WITH NOTIFICATION) SEQUENCE DIAGRAM (2)	45
FIGURE 4.2-9 LABORATORY– ABORT ORDER (WITH NOTIFICATION) SEQUENCE DIAGRAM (2)	45

CONFIDENTIALITY STATEMENT:

The Ministry of Health (MOH) of the Kingdom of Saudi Arabia grants to any user of this document, perpetual, royalty-free, nontransferable, nonexclusive, license under its copyrights to access and read the Saudi eHealth Specification. You may not reproduce or use this document or any portion of it, without prior written consent from the MOH. The licenses covered are only to those parts owned or controlled by the MOH itself. If parts of the Saudi eHealth Specification include materials owned or controlled by other parties, licenses to use those products would have to be obtained from that other party.

The MOH offers the licensed material as-is and as-available, and makes no representations or warranties of any kind concerning the licensed material, whether express, implied, statutory, or other. This includes, without limitation, warranties of title, merchantability, fitness for a particular purpose, non-infringement, absence of latent or other defects, accuracy, or the presence or absence of errors, whether or not known or discoverable. To the extent possible, in no event will the authors and licensor be liable on any legal theory (including, without limitation, negligence) or otherwise for any direct, special, indirect, incidental, consequential, punitive, exemplary, or other losses, costs, expenses, or damages arising out of this public license or use of the licensed material, even if the licensor has been advised of the possibility of such losses, costs, expenses, or damages.

Document Revision History

Version	Date	Type of update	Prepared
1.0	February 22, 2015	First Release	eHealth Strategy Management Office – eHealth Standards Department

1. INTRODUCTION

1.1 DOCUMENT PURPOSE

The purpose of this document is to address the Saudi eHealth Core Interoperability Specification for Sharing Coded Laboratory Orders. It forms a set of requirements that complements the set of IHE Profiles, HL7 and LOINC standards required by this specification with Saudi eHealth specific constraints. It also aligns with the Saudi e-Government Interoperability Standards (YEFI) to expedite national adoption.

This Interoperability Specification is applicable to existing and new information systems to be connected to the national Saudi eHealth Exchange (SeHE) platform.

1.2 DESCRIPTION

This Interoperability Specification establishes the initiation of a Coded Laboratory Order and making the order accessible via the SeHE platform. It addresses two types of Laboratory Orders:

- Laboratory Orders that are created by Healthcare Provider and/or Organization to perform laboratory tests on their patients. Laboratory test facilities (i.e. hospital, private and national laboratory centers) access the coded orders and fulfill the order.
- Laboratory Orders created by laboratories that rely on other laboratories to perform tests that cannot be performed locally. For example, small Healthcare Organization laboratories typically only perform common tests and use a regional or national laboratory for advanced tests.

A Laboratory Order is made up of a requested test or a battery of requested tests ordered by a physician or other authorized personnel. These tests are to be performed on specimens collected from the patient, in general by a laboratory or the Healthcare Organization ordering the laboratory tests. The actual ordered test or batteries of tests are specified by using structured codes, therefore they are termed as “Coded Laboratory Orders”.

1.3 SCOPE

In Scope:

The scope of this document is the specification of Shared Coded Laboratory Orders.

The scope of this document is further constrained as follows:

- Laboratory orders may only be shared for patients with KSA-Wide Health IDs
- Shared laboratory tests may only be ordered and fulfilled by a provider and/or organization authorized by the KSA.
- Existing shared coded Laboratory Orders may only be cancelled by a provider and/or organization authorized by the KSA.

Out of scope:

The following is a list of content and specifications that are specifically out of scope for this Interoperability Specification:

- Medical Practices for identifying authorized Healthcare Providers and/or Organizations is out of scope for this document.
- The User Interface for querying and retrieving Laboratory Order documents
- Laboratory sub-contracting is out of scope for this Use Case. As such, existing laboratory processes will be used to handle sub-contracted laboratory work, and the primary Laboratory will be responsible for updating the Laboratory Order and reporting the results report(s).
- The process by which orders are linked to shared Laboratory Orders is out of scope for this Specification
- A Shared Laboratory Order will be available to the laboratory prior to a patient going to a laboratory to have a specimen collected. The actual scheduling of the specimen collection at the laboratory is out of scope for this Specification.
- The physical labeling of the specimen to ensure that it can be matched to the patient's Laboratory Order is out of scope for this Specification.
- An individual Shared Laboratory Order will contain requested tests for only one specialty area (laboratory department). If requested tests are required for multiple specialty areas, it is the responsibility of the Laboratory Order Creator to split the Laboratory Order into shareable Laboratory Orders. Likewise, the Laboratory Order Creator is required to maintain the linkage to the individual shareable Laboratory Orders and their statuses in order to determine the status of the original Laboratory Order. This process is out of scope for this Specification.
- The Medical Practices/Policies associated with discarding specimens because of cancelled Laboratory Orders is out of scope for this Specification.
- The workflow for performing the Laboratory Order is outside the scope of this Specification. Examples of workflows include which organization performs the test and how the patient is notified that the results are available (e-mail, phone call).

1.4 RELATIONSHIP BETWEEN LABORATORY ORDERS AND RESULTS REPORTS

The operation of the sharing of Laboratory Orders and Results Reports is covered by two different interoperability specifications, one addressing orders and the second addressing results. The specification of the Laboratory order workflow (i.e. the placement of a Laboratory Order and completion of a Laboratory Order) as well as the Laboratory Order interoperability are covered by the *Saudi eHealth Core Interoperability Specification for Coded Laboratory Order*. The specification of the Laboratory Results Report creation (including updates and access) as well as the Laboratory Results Report interoperability are covered by the *Saudi eHealth Core Interoperability Specification for Sharing Coded Laboratory Results*. Figure 1.4 1: Overview of relationship between Shared Coded Lab Results and Coded Lab Orders Interoperability Specifications

Figure 1.4-1: Overview of Relationship between Shared Coded Lab Results and Coded Lab Orders Interoperability Specifications depicts the major activities associated with the creation and execution of a Laboratory Order and the creation of the Laboratory Results Report,

the associated workflow and how the requirements for the interoperability specification are divided up.

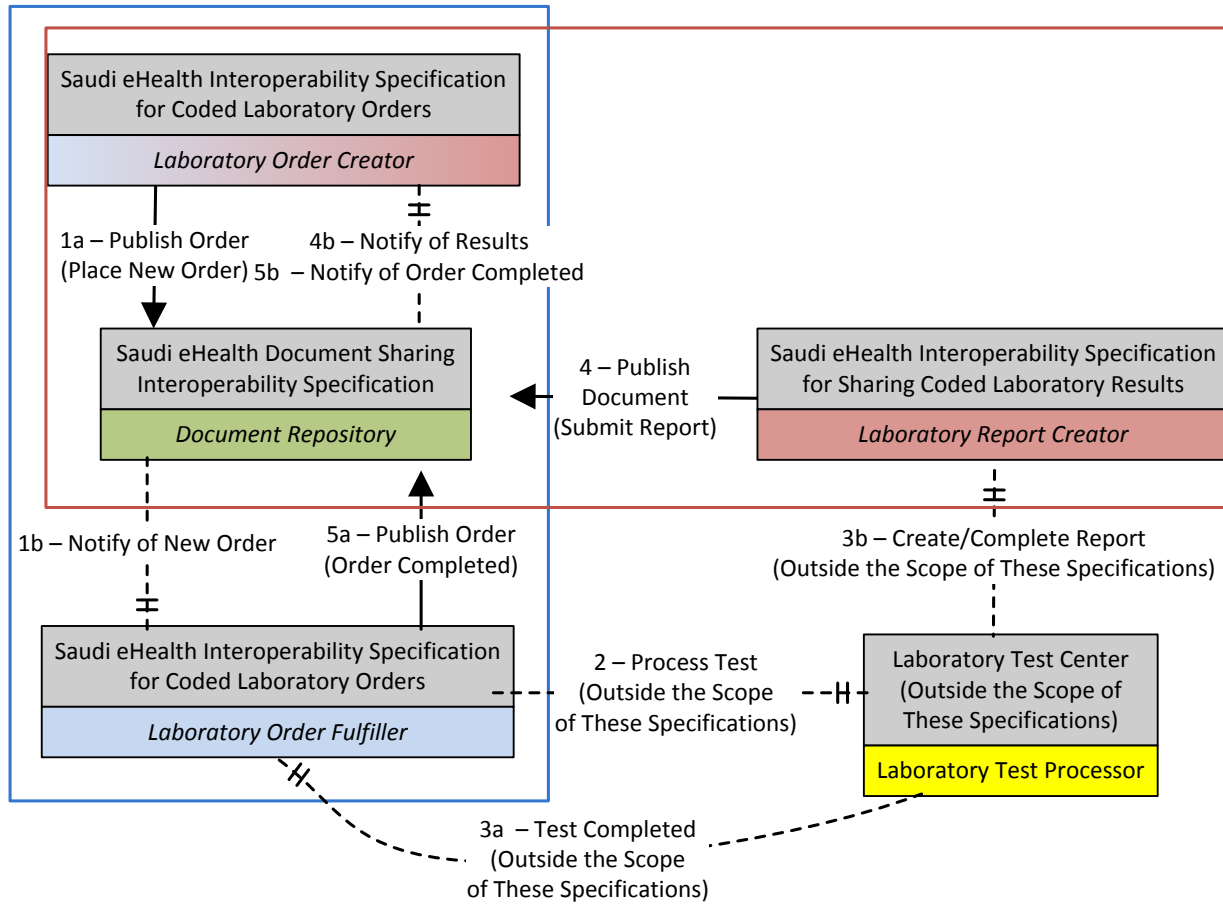

FIGURE 1.4-1: OVERVIEW OF RELATIONSHIP BETWEEN SHARED CODED LAB RESULTS AND CODED LAB ORDERS INTEROPERABILITY SPECIFICATIONS

1.5 METHODOLOGY

This Interoperability Specification has been developed with input from various Saudi stakeholders collected during several months through workshops and teleconferences. Stakeholders giving input included clinicians and leaders from numerous laboratories at several Healthcare Organizations handling laboratory workflows in facilities.

The development of a Core Interoperability Specification relies on the high-level requirements set by the associated Use Case. These high-level requirements are not restated in this specification and readers may consider reviewing the related Saudi eHealth Use Case Specification document.

1.6 HOW TO READ THIS DOCUMENT

1.6.1 Where to Find Information

This document contains four normative sections, as well as informative appendices for convenience. The document is structured as follows:

Section 1: Contains an introduction to the Interoperability Specification (IS). This section contains a summary of the IS purpose and scope, as well as other content to help orient the first time reader to the topic of the IS and how it relates to other specifications in the SeHE architecture.

Section 2: Describes the Use Case, including design constraints and assumptions and the flows of information that will be specified in this IS. Section 2 also introduces scenarios that describe how the specified flows may be used in the Saudi eHealth context.

Section 3: Provides an overview of how the interoperability requirements fit into the overall context of the Use Case.

Section 4: Establishes the Core Interoperability Requirements for the Interoperability Specification. Diagrams within this section show only cross business actor transactions. Actions internal to the business actors have been omitted from the diagrams for brevity and clarity.

Section 5: Establishes the Conformance Requirements for the Interoperability Specification

Section 6: Describes the constraints on the sharing of laboratory results with specific requirements for the Order Creator, Order Fulfiller and Document Repository

Section 7: Lists the Saudi eHealth reference documents, as well as the international standards which underpin the Interoperability Specification.

Appendix A: Illustrates example messages and documents used with this Specification

1.6.2 Related Documents

The Saudi eHealth Core Interoperability Specification (IS) is the sole entry point for the technology developers, compliance assessment testing and certification, and the purchaser of IT systems in term of technical requirements.

It references a number of supporting Interoperability Specifications:

- IS0001 *Saudi eHealth Core Interoperability Specification for KSA-Wide Patient Demographic Query*
- IS0003 *Saudi eHealth Core Interoperability Specification for Sharing Coded Laboratory Results*
- IS0101 *Saudi eHealth Security and Privacy Interoperability Specification*
- IS0102 *Saudi eHealth Document Sharing Interoperability Specification*
- IS0105 *Saudi eHealth Laboratory Results and Orders Content Interoperability Specification*
- IS0106 *Saudi eHealth Clinical Documents Constrains Interoperability Specifications*
- IS0200 *Saudi eHealth Terminology Repository*

See Table 7-1 Internal References for more information on these supporting Interoperability Specifications.

The above Saudi eHealth Interoperability Specifications include precise references to internationally adopted profiles and standards as well as Saudi specific constraints.

Implementations are required to conform to the requirements within this Interoperability Specification as well as all referenced Interoperability Specifications and the standards and profiles they specify.

This document fits into an overall specification framework described in Figure 1.6.2-1 Coded Laboratory Orders Document Organization. Further descriptions and references for the documents identified below are provided in Section 7: Referenced Documents And Standards

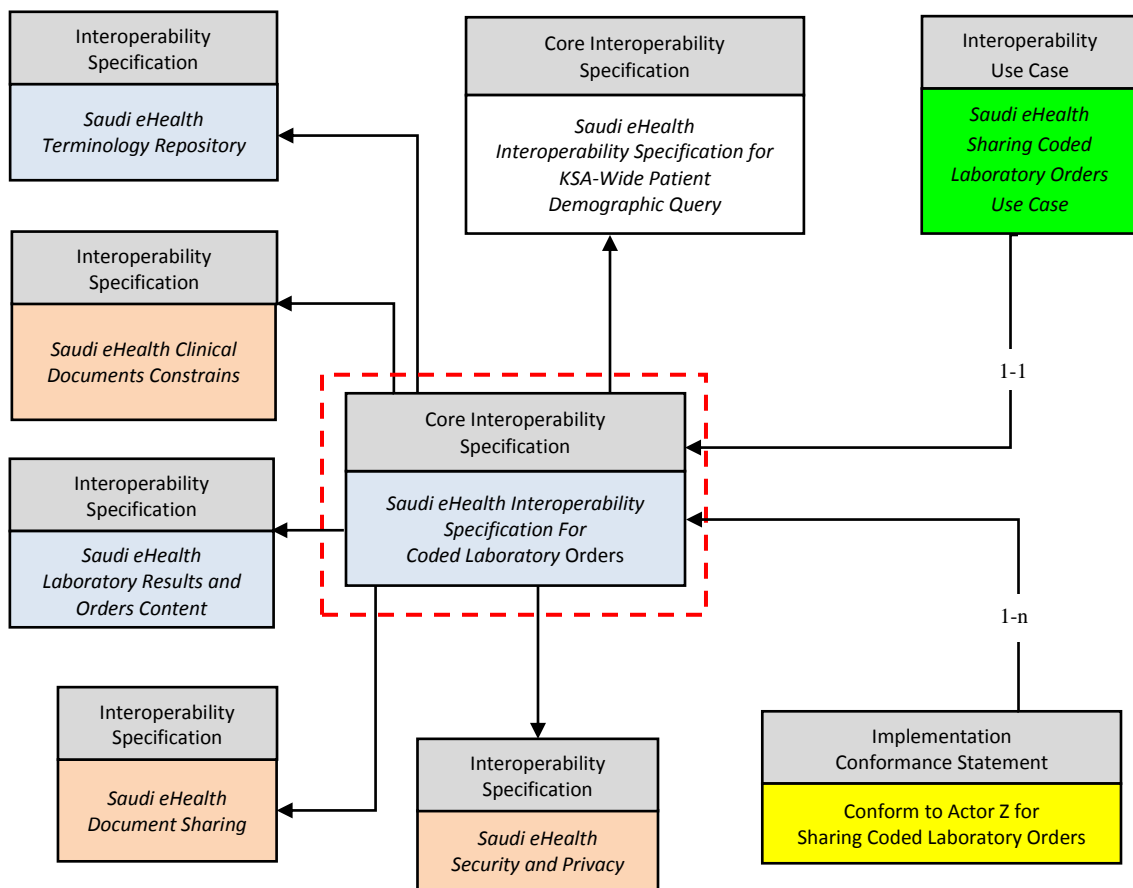

FIGURE 1.6.2-1 CODED LABORATORY ORDERS DOCUMENT ORGANIZATION

1.6.3 Document Conventions

1.6.3.1 REQUIREMENTS NUMBERING CONVENTIONS:

All Saudi eHealth Interoperability Specifications contain numbered requirements that follow this format:

- [ABCD-###], where ABCD is a three or four letter acronym unique to that Interoperability Specification for convenient purposes, and ### is the unique number for that requirement within the Interoperability Specification.
- Where a specific value set or code is required to be used, it can be found in the “IS0200 Saudi eHealth Terminology Repository”. The location and process to access the terminology repository will be specified in mechanisms external to this document.

Saudi eHealth numbered requirements are the elements of the Interoperability Specification that the system conforms to. In other words, in order to implement a system that fully supports the Use Case and Interoperability Specification, the system shall be able to demonstrate that it conforms to every numbered requirement for the system actors to which it is claiming conformance.

Please note that all Saudi eHealth numbered requirements are numbered uniquely, however numbered requirements are not always sequential.

1.6.3.2 REQUIREMENTS LANGUAGE

Throughout this document the following conventions¹ are used to specify requirement levels:

SHALL: the definition is an absolute requirement of the specification. (Note: “SHALL IF KNOWN” means that the tag must be sent. However, if there were no information, then this tag should be sent with a <nullflavor>).

SHALL NOT: the definition is an absolute prohibition of the specification.

SHOULD: there may exist valid reasons in particular circumstances to ignore a particular item, but the full implications must be understood and carefully weighed before choosing a different course.

SHOULD NOT: there may exist valid reasons in particular circumstances when the particular behavior is acceptable or even useful, but the full implications should be understood and the case carefully weighed before implementing any behavior described with this label.

MAY or **OPTIONAL:** means that an item is truly optional. One vendor may choose to include the item because a particular marketplace requires it or because the vendor feels that it enhances the product while another vendor may omit the same item.

¹ Definitions based upon RFC 2119

2. USE CASE

2.1 USE CASE ACTORS AND SERVICES

The Use Case Actors and the Services that are used by this Core Interoperability Specification are described at a functional level in the Saudi eHealth Coded Laboratory Orders Interoperability Use Case: Section 3.3. A brief description is provided in the following tables.

TABLE 2.1-1 USE CASE ACTORS

Actor Name	Description
Document Repository	This Repository stores the Coded Laboratory Orders for access by both the Laboratory Order Creator and Laboratory Order Fulfiller Actors.
Laboratory Order Creator	This Actor is responsible for the creation of Coded Laboratory Orders as an electronic order and publishing the order to the Document Repository. It also manages the order status such as new order or cancelled.
Laboratory Order Fulfiller	This Actor is responsible for querying and retrieving Coded Laboratory Orders from the Document Repository for their fulfillment. It is also responsible to provide updates to the order, such as completed or aborted.

TABLE 2.1-2 USE CASE SERVICES

Service Name	Description
Publish Order	Publish Order is used to create and manage the Laboratory Order with statuses such as in-process, completed, cancelled and aborted to the Document Repository.
Query/Retrieve Order	Query the Document Repository for information about stored orders. It is also used to retrieve Coded Laboratory Orders.
Notification of Document Availability	This service is issued by the Document Repository to notify a Laboratory Order Fulfiller Actor of a Laboratory Order of interest that is available to be retrieved. This service is also used to notify the Laboratory Order Creator Actor that a Laboratory Order of interest has been updated, such as completed or aborted.

2.2 DESIGN CONSTRAINTS AND ASSUMPTIONS

The following design principles underlie this interoperability specification:

It is expected that all services initiated or provided by these Actors operate in accordance to the Saudi eHealth Health Information Exchange Policies.

- Laboratory orders can only be shared for patients with KSA-Wide Health IDs.
- The Saudi eHealth System has been designed with the assumption that Systems will be primarily on-line. Functionality is built into the SeHE System to re-try if a System is unavailable.
- Only a Healthcare Provider and/or Organization authorized by the KSA can determine that one or more shared laboratory tests can be ordered for a patient.

- Only an authorized Healthcare Provider and/or Organization can cancel an existing Shared Coded Laboratory Order.
- Only an authorized Laboratory can abort an existing Shared Coded Laboratory Order that it has started.
- The laboratory is authorized by the KSA to perform laboratory tests.
- The specimen collection will be performed either at the location the Laboratory Order is created, or at the laboratory where the Laboratory Order will be performed.
- The Patient Identifier, the Placer Order Number and the Specimen Identifier must be transmitted with the specimen to enable the receiving laboratory to retrieve a shared order upon receipt.
- The receiving laboratory is responsible for ensuring that the specimen information is included in all orders it accepts for processing regardless of how the specimen is obtained.
- An individual Shared Laboratory Order will contain requested tests for only one specialty area (laboratory department). If requested tests are required for multiple specialty areas, it is the responsibility of the Laboratory Order Creator to split the Laboratory Order into Shareable Laboratory Orders. Likewise, the Laboratory Order Creator is required to maintain the linkage to the individual Shareable Laboratory Orders and their statuses in order to determine the status of the original Laboratory Order.
- Only verified results report(s) will be shared.
- Medical Practices will determine the content of the Documentation required to cancel a test within the Laboratory Order.
- Medical Practices will determine the content of the Documentation required to abort a test within the Laboratory Order.
- Medical Practices will determine the ability for a laboratory to Modify or Add requested tests to a Laboratory Order.
- The Query and Retrieve capabilities of Laboratory Orders are governed by SeHE Exchange Policies.
- Document Metadata Subscription to receive notifications is expected to happen at the install/configuration time. This simplifies implementation until specific need for dynamic subscription has been identified. For further details, see the IS0103 *Saudi eHealth Document Sharing Interoperability Specification*.

2.3 USE CASE FLOW OF EVENTS

The Saudi eHealth Interoperability Use Case document describes the key workflows that are supported by this Core Interoperability Specification. A brief summary of the Use Case flows are provided below. For an in-depth understanding of the Use Case flows, it is recommended that one should read the Use Case document.

- **Main Flow:** An authorized Healthcare Provider and/or Organization (i.e. Laboratory Order Creator) creates a coded Laboratory Order and publishes the order on the Document Repository. The Document Repository resides in SeHE platform. The edge systems that are fulfillers of a Laboratory Order (i.e. Laboratory Order Fulfiller) retrieve the coded Laboratory Order from the Document Repository, collect the necessary sample(s) and perform the requested test(s). The Laboratory Results Report(s) are published to the Document Repository. The Healthcare Provider and/or Organization may be notified about the completion of the order. Upon successful completion of the coded Laboratory Order, one or more Laboratory Results Reports are generated.
- **Alternative Flow of Events:** This workflow may be implemented when it is determined that some or all of the tests ordered by the Healthcare Provider and/or Organization cannot be performed locally; and therefore, the services of a Regional Laboratory are needed. A specimen is taken from the patient, a Coded Laboratory Order is created, and the sample is manually shipped to a Regional Laboratory. The Coded Laboratory Order is published on the Document Repository. Edge systems that fulfill Laboratory Orders may be notified when the orders are accessible within the Document Repository.
- **Exception Workflow:** The authorized Healthcare Provider and/or Organization decides to cancel the Laboratory Order (e.g. change of condition for the patient) that has not been started. Using the Laboratory Order Creator, the Laboratory Order is updated with the Laboratory Order status of “cancelled” and information is provided on why the Laboratory Order was cancelled.
The cancelled order is stored on the Document Repository. When the Laboratory Order Fulfiller queries for the order (for example when it received the patient’s specimen) it learns the Laboratory Order has been cancelled, therefore does not perform the test.

Exception Workflow: A coded Laboratory Order is retrieved from the Document Repository by the Laboratory Order Fulfiller, and matched to the patient’s specimen. The laboratory determines that the specimen is inappropriate to perform the requested test(s). The Laboratory Order Fulfiller updates the Laboratory Order status to “aborted” and provides information on why the Laboratory Order was aborted. The Laboratory Order Fulfiller sends the updated order to the Document Repository. The Document Repository sends a notification to the Laboratory Order Creator that retrieves and takes necessary action on the aborted Laboratory Order, such as following up with the patient for fresh specimen etc.

2.3.1 Specific Workflow Scenarios

2.3.1.1 SCENARIO 1: LABORATORY ORDER FULFILLER PROCESSES A SUCCESSFUL ORDER SUBMITTED REMOTELY

A Laboratory Order Fulfiller receives a notification from the Document Repository that a Laboratory Order has been created. It queries the Document Repository, finds and retrieves the order document. The Laboratory Order Fulfiller recognizes that a specimen has been collected by

the ordering system, and must wait for the sample to be received before the Laboratory Order can be started.

When the sample is received and matched to the previously retrieved order, the Laboratory Order Fulfiller queries the Document Repository to check if the Laboratory Order has been updated. The Laboratory Order Fulfiller updates the Laboratory Order with the specimen receipt information and updates the Laboratory Order status to “active” (in-process), and an updated Laboratory Order is sent to the Document Repository. The laboratory performs the requested test(s) and stores the Laboratory Results Report(s) to the Document Repository (See IS0003 *Saudi eHealth Core Interoperability Specification for Sharing Coded Laboratory Results for details*). Upon completing the Laboratory Order and storing the Laboratory Result Report(s) to the Document Repository, the Laboratory Order Fulfiller updates the Laboratory Order status to “completed” and an updated Laboratory Order is sent to the Document Repository. The Document Repository sends a notification to the ordering system (i.e. the original Laboratory Order Creator) that retrieves the “completed” Laboratory Order.

This scenario is a sub-set of the Use Case main flow of events.

2.3.1.2 SCENARIO 2: PATIENT VISITS THE LABORATORY ORDER FULFILLER TO PROVIDE A SPECIMEN FOR LABORATORY TESTS ORDERED BY THE LABORATORY ORDER CREATOR

A patient visits a remote laboratory as per the instruction of the Ordering Provider who has ordered laboratory tests for the patient. The patient is processed through the registration process and the patient’s KSA-Wide Health ID is used to retrieve the Laboratory Order from the Document Repository. The Laboratory Order Fulfiller verifies that there is a “new” Laboratory Order and that the sample has not been collected by the Ordering Provider (i.e. the Laboratory Order Creator).

Sample(s) are locally collected at the laboratory. The Laboratory Order Fulfiller updates the Laboratory Order with the specimen information and updates the Laboratory Order status to “active” (in-process), and an updated Laboratory Order is sent to the Document Repository. The laboratory performs the requested test(s) and stores the Laboratory Results Report(s) to the Document Repository (See the IS0003 *Saudi eHealth Core Interoperability Specification for Sharing Coded Laboratory Results for details*). Upon completing the Laboratory Order, and storing the laboratory result report(s) to the Document Repository, the Laboratory Order Fulfiller updates the Laboratory Order status to “completed” and an updated order is sent to the Document Repository. The Document Repository sends a notification to the ordering system (i.e. the original Laboratory Order Creator) that retrieves the “completed” Laboratory Order.

This scenario is a sub-set of the Use Case Alternative Flow events.

2.3.1.3 SCENARIO 3: LABORATORY ORDER IS CANCELLED BEFORE IT HAS BEEN PROCESSED BY A REMOTE LABORATORY

An authorized Laboratory Order Creator determines that a previously Shared Laboratory Order is no longer needed. The Laboratory Order Creator queries the Document Repository to check if

the Laboratory Order has already been started. Finding that the Laboratory Order status is still “new”, the Laboratory Order Creator updates the Laboratory Order in the Document Repository with a Laboratory Order status of “cancelled”, and a comment indicating the reason why the Laboratory Order is being cancelled.

Note: Only the Order Creator can cancel the Laboratory Order.

Upon receiving the sample, the Laboratory Order Fulfiller retrieves the matching Laboratory Order from the Document Repository for processing. The laboratory technician reviews the Laboratory Order and determines it has been cancelled. Following laboratory protocol, the sample is discarded and no testing is performed.

This scenario is a sub-set of the Use Case Exception Flow 1 events.

2.3.1.4 SCENARIO 4: A LABORATORY ORDER IS UPDATED BY AN ORDER CREATOR BEFORE PROCESSING BY A REMOTE LABORATORY

An authorized Laboratory Order Creator determines that a previously Shared Laboratory Order needs to be modified (e.g. additional tests). The Laboratory Order is amended with the modified Laboratory Order information, but the status of the Laboratory Order sent to the Document Repository remains “new”.

The Laboratory Order Fulfiller retrieves the Laboratory Order for processing. The laboratory reviews the amended Laboratory Order and performs it.

This scenario is a sub-set of the Use Case main flow of events.

2.3.1.5 SCENARIO 5: LABORATORY ORDER IS PROCESSED BY A REMOTE LABORATORY AND IS ABORTED

Upon receiving the sample, the Laboratory Order Fulfiller retrieves the matching Laboratory Order from the Document Repository for processing. The laboratory technician determines the sample is inappropriate to perform the requested test(s). The Laboratory Order Fulfiller updates the Laboratory Order in the Document Repository with a Laboratory Order status of “aborted” and a comment indicating the reason why the Laboratory Order is being aborted. The Document Repository sends a notification to the ordering system (i.e. the original Laboratory Order Creator). The ordering provider retrieves the “aborted” Laboratory Order.

This scenario is a sub-set of the Use Case Exception Flow 2 events.

2.3.1.6 SCENARIO 6: ATTEMPT TO CANCEL A LABORATORY ORDER THAT HAS ALREADY BEEN PROCESSED BY A REMOTE LABORATORY

The remote laboratory has received a sample to be processed. Using the patient’s KSA-Wide Health ID, the Laboratory Order Fulfiller retrieves the Laboratory Order and verifies that the Laboratory Order has not already been started (the laboratory status is “new”). The Laboratory Order Fulfiller updates the Laboratory Order with the specimen information and the updated

Laboratory Order status of “active”. The Laboratory Order Fulfiller attempts to amend the Laboratory Order in the Document Repository.

Simultaneously, the authorized Ordering Provider determines that the requested laboratory tests are no longer needed. The Laboratory Order Creator queries the Document Repository to check if the Laboratory Order has already been started. Finding that the Laboratory Order status is still “new”, the Laboratory Order Creator attempts to update the Laboratory Order in the Document Repository with a Laboratory Order status of “cancelled”, and a comment indicating the reason why the Laboratory Order is being cancelled.

If the Laboratory Order Fulfiller’s Laboratory Order update to the Document Repository occurs first, the Laboratory Order Creator’s attempt to change the Laboratory Order in the Document Repository to be “cancelled” will fail (See *IS0102 Saudi eHealth Document Sharing Interoperability Specification* on publishing behavior). At this point the Laboratory Order Creator will need to re-query and retrieve the updated Laboratory Order to determine that the Laboratory Order was made “active”.

Likewise, if the Laboratory Order Creator’s Laboratory Order update to the Document Repository occurs first, the Laboratory Order Fulfiller’s attempt to amend the Laboratory Order in the Document Repository to in-process will fail.(See the *IS0102 Saudi eHealth Document Sharing Interoperability Specification* on publishing behavior).At this point the Laboratory Order Fulfiller will need to re-query and retrieve the updated Laboratory Order to determine that the Laboratory Order was “cancelled”. The Laboratory Order Fulfiller will need to follow the process for cancelled Laboratory Orders.

This scenario is a sub-set of the Use Case Exception Flow 1 flow of events.

2.3.1.7 SCENARIO 7: PATIENT WITHOUT KSA-WIDE HEALTH ID COMES IN AND THE LABORATORY TEST NEEDS TO BE PERFORMED REMOTELY

A patient requiring remote laboratory work has no KSA-Wide Health ID. Without a KSA-Wide Health ID Laboratory Orders cannot be shared through the Document Repository. The options are to obtain a KSA-Wide Health ID for the patient prior to commencing with the Laboratory Order (in which case the standard workflow applies) or to create a paper Laboratory Order for the patient to take with them to the remote laboratory.

Following local protocol, samples will be collected and identified along with local identification of the patient and the paper Laboratory Order. The laboratory will perform the requested tests using their local protocol, and store the Laboratory Results Report locally. Until such time that a KSA-Wide Health ID is assigned to the patient, the Laboratory Results Report(s) cannot be stored or shared through the Document Repository (See *IS0003 Saudi eHealth Core Interoperability Specification for Sharing Coded Laboratory Results*). Local laboratory protocol must be used to share the Laboratory Results Report(s) with the ordering provider. This scenario defines local workflow that is outside the scope of the Use Case. Once the KSA-Wide Health ID is identified this scenario follows the Use Case main flow of events.

2.3.1.8 SCENARIO 8: LABORATORY ORDER REQUIRES MULTIPLE LABORATORY SPECIALTIES TO FILL A LABORATORY ORDER

A Healthcare Provider creates a Laboratory Order which requires tests from multiple laboratory specialties (e.g. hematology and microbiology). Using a process which is out of scope for this Use Case, the Laboratory Order Creator divides the Laboratory Order into multiple Laboratory Orders, each containing requested test(s) for an individual laboratory specialty. The Laboratory Order Creator will be responsible for maintaining the linkages between the original Laboratory Order and the single specialty Laboratory Orders through the use of Placer Order Numbers which uniquely identify the Laboratory Orders within the SeHE environment.

The single specialty Laboratory Orders are sent to the Document Repository and performed as individual Laboratory Orders. Each Laboratory Order Fulfiller associated with a Laboratory Order will perform the requested test(s) and create Laboratory Results Report(s) which will be sent to the Document Repository. The Laboratory Order Fulfiller will be responsible for maintaining the linkages between the single specialty Laboratory Order and the Laboratory Results Report(s) through the use of Filler Order Numbers and Placer Order Numbers. The Filler Order Number is the unique identifier assigned by the laboratory or their information system when the tests were performed (e.g. accession number). The Placer Order Number is the unique identifier created by the requestor or their information system when the order was placed to produce the Laboratory Results Report within the SeHE environment.

This scenario is a sub-set of the Use Case main flow of events.

2.3.1.9 SCENARIO 9: REMOTE LABORATORY PROCESSES A LABORATORY ORDER AND PROVIDES PARTIAL RESULTS

The laboratory performs some of the requested test(s) but is unable to perform some of the tests (e.g. equipment failure, resource failure or insufficient sample). The Laboratory Results Reports for the completed tests are stored to the Document Repository (See the IS0003 *Saudi eHealth Core Interoperability Specification for Sharing Coded Laboratory Results* for details). The Laboratory Order Fulfiller updates the status of the individual requested test(s) aborted to “aborted”, adding a comment to the individual requested test(s) which have been aborted as to the reason. The Laboratory Order status is moved from “active” to “completed” indicating that no further action will be taken on the Laboratory Order.

The ordering Healthcare Provider is notified by the Document Repository that partial results are available, but the Laboratory Order has been completed. By retrieving the amended Laboratory Order and reviewing the reason why the requested test(s) were aborted, the ordering Healthcare Provider can take the appropriate actions to get the appropriate laboratory tests completed.

This scenario is a sub-set of the Use Case main flow of events.

2.3.1.10 SCENARIO 10: LABORATORY ORDER IS TRANSFERRED FROM ONE LABORATORY TO ANOTHER AND THEN PROCESSED SUCCESSFULLY

A Laboratory Order Fulfiller finds and retrieves an order document from the Document Repository. The Laboratory Order Fulfiller updates the Laboratory Order status to “active” (in-process), and an updated Laboratory Order is sent to the Document Repository. Prior to performing the requested test(s) the laboratory determines that there are unable to perform the

requested test(s) (e.g. equipment failure). Using laboratory protocol, the laboratory is able to make arrangements for another laboratory to perform the requested tests.

The Laboratory Order Fulfiller amends the Laboratory Order with information on the alternative laboratory that is to perform the requested test(s), a comment on the reason why it is relinquishing the Laboratory Order and updates the Laboratory Order status back to “new”. The Laboratory Order Fulfiller sends the updated Laboratory Order to the Document Repository. The laboratory manually ships the sample to the alternative laboratory. The Laboratory Order Fulfiller from the alternative laboratory receives a notification from the Document Repository that there is Laboratory Order for them to perform.

This scenario is a sub-set of the Use Case main flow of events.

2.3.1.11 SCENARIO 11: A LABORATORY ORDER IS MODIFIED BY AN ORDER FULFILLER WHILE IT IS BEING PROCESSED BY A LABORATORY

A Laboratory Order Fulfiller finds and retrieves an order document from the Document Repository. The Laboratory Order Fulfiller updates the Laboratory Order status to “active” (in-process), and an updated Laboratory Order is sent to the Document Repository. The laboratory begins to perform the requested test(s) and determines that an amendment is needed to the Laboratory Order (e.g. different test(s) need to be performed; additional tests need to be performed). Using the laboratory protocol, the Laboratory Order Fulfiller amends the Laboratory Order with the updated information and sends it to the Document Repository. The laboratory continues performing the amended Laboratory Order.

This scenario is a sub-set of the Use Case main flow of events.

2.3.1.12 SCENARIO 12: LABORATORY ORDER IS PUT ON HOLD AND THEN RELEASED.

A Laboratory Order Fulfiller finds and retrieves an order document from the Document Repository. The Laboratory Order Fulfiller updates the Laboratory Order status to “active” (in-process), and an updated Laboratory Order is sent to the Document Repository. The laboratory starts to perform the requested test(s). During the execution it is determined that the laboratory cannot complete the requested test(s) (e.g. additional sample is required, laboratory work is sub-contracted); however, it is decided that eventually the laboratory will be able to complete the requested testing. Based upon laboratory protocol, the Laboratory Order Fulfiller updates the Laboratory Order status to “suspend”, and an updated Laboratory Order is sent to the Document Repository. The laboratory temporarily stops work on the requested test(s) until the reason for placing the Laboratory Order on hold is resolved.

This scenario is a sub-set of the Use Case main flow of events.

2.3.1.13 SCENARIO 13: A LABORATORY ORDER ON HOLD IS RESUMED

The laboratory determines that the reason for suspending a Laboratory Order has been resolved. The Laboratory Order Fulfiller finds and retrieves the order document from the Document Repository and amends the Laboratory Order with whatever Laboratory Order information is necessary, and updates the Laboratory Order status to “active” (in-process). The Laboratory

Order Filler sends the updated Laboratory Order to the Document Repository. The laboratory continues performing the requested test(s).

This scenario is a sub-set of the Use Case main flow of events.

2.3.1.14 SCENARIO 14: QUERY LABORATORY ORDERS

An Ordering Healthcare Provider needs to determine the status of a Patient's Laboratory Orders. The Ordering Healthcare Provider is able to query and retrieve shared orders using filtering mechanisms managed by the shared Document Repository and/or local applications.

When shared Laboratory Orders are created, the documents are stored in the Document Repository with key metadata attributes which can be used to filter the information about Laboratory Orders returned from a Document Repository query.

Three levels of filtering are available to the application user and the application internal capabilities:

- The first level of query is managed by the shared Document Repository and based on one or more query attributes which provide enough specificity (e.g. patient KSA-Wide Health ID, laboratory specialty, service time, etc.) to select relevant Laboratory Orders. Typical query attributes include:
 - Patient KSA-Wide Health ID
 - Requested Laboratory tests (e.g. A1C, Metabolic Panel, Blood Culture)
 - Laboratory Order Status (e.g. only New Orders, In-Process Orders, Suspended Orders, Completed Orders, Aborted Orders)
 - Laboratory specialty (biochemistry, microbiology, etc.)
 - Time interval of service order request
- The second level filtering may be applied on the returned metadata attributes associated with an order to provide an additional level of filtering on the query responses. These include the above attributes plus other such as Ordering Provider (Laboratory Order author).
- The third level of filtering can be performed by a local application, and the specification of this query is out of scope for IS0004 *Saudi eHealth Core Interoperability Specification for Coded Laboratory Orders*.

Note: If Laboratory Orders have a confidentiality level associated with them (e.g. restricted test such as HIV Test), a Healthcare Provider is only allowed to access Laboratory Orders with a lower confidentiality level; and therefore, may not be able to access the data from restricted Laboratory Orders associated with the Patient although the filters at the above levels would not have excluded them (See IS0101 *Saudi eHealth Security and Privacy Interoperability Specification*).

3. OVERVIEW OF WORKFLOWS

3.1 LABORATORY ORDER WORKFLOW

The paradigm of the Shared Laboratory workflow differs from the standard in-house Laboratory workflow in that the Laboratory updates are only made to the Shared Laboratory Order only when the information needs to be shared within the SeHE System. The following section describes the workflow of a Shared Laboratory Order as well as the workflow of the Specimen(s) required to complete the Laboratory Order.

The Shared Laboratory Order is stored in the Document Repository as a document. The Shared Laboratory Order is only updated when the Healthcare Provider and/or Organization, or the laboratory want to share the updates, otherwise interim changes are maintained internal to the organization. The Shared Laboratory Order may not contain all of the data stored in local information systems used to manage ordering and test execution, only that information which must be shared between the ordering provider and the fulfilling laboratory. The Shared Laboratory Order document represents a point in time for the Laboratory Order. The Laboratory Order status within the Laboratory Order document represents the latest state of the Laboratory Order stored in Document Repository. Figure 3.1-1: Laboratory Order Transition State Diagram depicts the transition states and the possible transitions which exist for a Shared Laboratory Order.

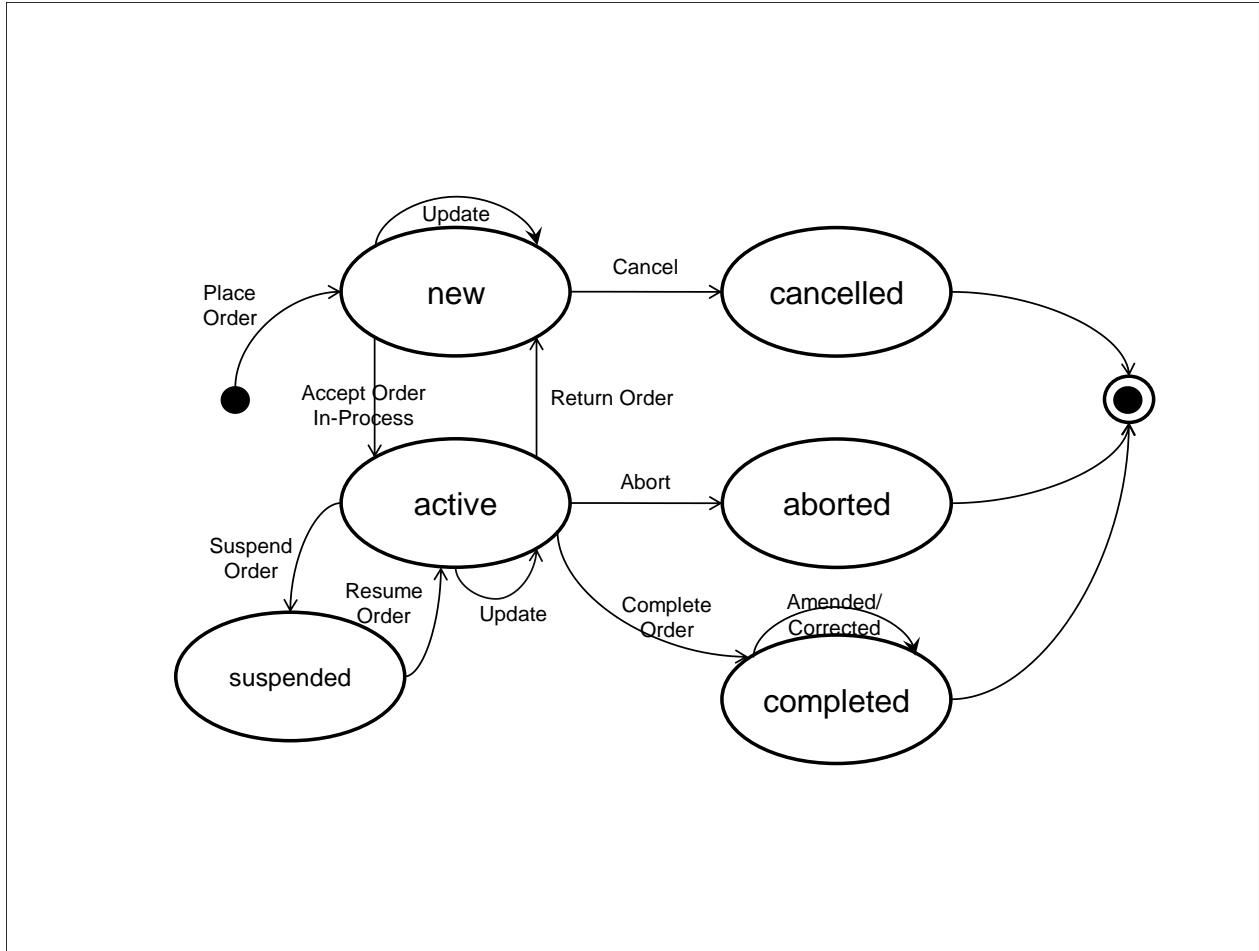

FIGURE 3.1-1: LABORATORY ORDER TRANSITION STATE DIAGRAM

There are two major organizations involved in the execution of a Shared Laboratory Order: the order placer (i.e. The Laboratory Order Creator) who initially creates the Shared Laboratory Order; and the laboratory (i.e. The Laboratory Order Fulfiler) who executes the shared Laboratory Order.

Table 3.1-1 Laboratory Order Status Actions by the Order Placer depicts the relationship between the Laboratory Order state and the relevant activities that can be done by the order placer.

TABLE 3.1-1 LABORATORY ORDER STATUS ACTIONS BY THE ORDER PLACER

Laboratory Order Action	Order Status	Specimen Status	Activities
Order Placed	NEW	May be Present or Absent	Send the Order document to the Document Repository
Order Updated	NEW	May be Present or Absent	Replace the Order document in the Document Repository

Laboratory Order Action	Order Status	Specimen Status	Activities
Order Cancelled	CANCELLED	N/A	No further action to be taken on the Order. Ordering Organization must document why the Order was cancelled. Replace the Order Document in the Document Repository.

Table 3.1-2 Laboratory Order Status Actions by the Laboratory depicts the relationship between the Laboratory Order state and the relevant activities that can be done by the Laboratory performing the Shared Laboratory Order.

TABLE 3.1-2 LABORATORY ORDER STATUS ACTIONS BY THE LABORATORY

Laboratory Order Action	Order Status	Specimen Status	Activities
Accept Order (In-Process)	ACTIVE	Specimen SHALL be present.	Laboratory now controls the Order (cannot be cancelled or updated by the organization who placed the order). Replace the Order Document in the Document Repository.
Order Updated (Active Order)	ACTIVE	Specimen SHALL be present.	Laboratory may update the Laboratory Order with Test Order or specimen information when the Order is in process. Replace the Order Document in the Document Repository. Laboratory may publish a partial Results Report linked to the Order while the Order is ACTIVE (this may be done independently of updating the Laboratory Order).
Return Order	NEW	Specimen SHALL exist	Laboratory may return a claimed Order if the tests haven't been started (e.g. failure equipment) for a different Laboratory to complete. Process of re-scheduling is out of scope. Laboratory must document why the Laboratory Order was returned. Replace the Order Document in the Document Repository.

Laboratory Order Action	Order Status	Specimen Status	Activities
Order Completed	COMPLETED	N/A	Laboratory has created and published a Results Report linked to the Order Replace the Order Document in the Document Repository.
Order Aborted	ABORTED	N/A	Laboratory must document why the testing was aborted. Laboratory may have created and published a Results Report linked to the Order to report Partial Results. Replace the Order Document in the Document Repository.
Order Suspended	SUSPENDED	Specimen exists, but a new one may be in the process of being collected to complete the testing.	Collection of additional Specimen to continuing the testing is out of scope. Replace the Order Document in the Document Repository.
Resume Order	ACTIVE	Specimen SHALL exist	Order is resumed when the laboratory is ready to continue. Order may need to be amended with additional specimen or other changes to the Laboratory Order. Replace the Order Document in the Document Repository.
Return Order	NEW	Specimen SHALL exist	Laboratory may return a claimed Order if the tests haven't been started (e.g. failure equipment) for a different Laboratory to complete. Process of re-scheduling is out of scope for this IS. Laboratory must document why the Laboratory Order was returned. Replace the Order Document in the Document Repository.
Amend/Correct Order	COMPLETED	Specimen SHALL exist	Updates to completed Laboratory Orders are only used to correct information Replace the Order Document in the Document Repository.

The laboratory may publish Laboratory Results Report(s) as long the Shared Laboratory Order is “active”. Saudi Laboratories Policies requires that all Laboratory Results Reports be validated by the laboratory prior to being shared. Therefore, unverified results cannot be shared, whereas

Partial Results can be. For example, in the case of a Wound Culture, a positive result for some kind of bacteria may be reported, but the result will not be marked complete (will be Partial) because susceptibility is still to be done. Once a Shared Laboratory Order is “completed” or “aborted”, it is expected that results reports will only be amended or corrected. For more information on the publishing of Laboratory Results Reports please see the related specification IS0003 *Saudi eHealth Core IS for Sharing Coded Laboratory Results*.

3.2 SPECIMEN WORKFLOW

Within the Saudi eHealth System, the collection of the specimen is collected either at the time the Shared Laboratory Order is created or at the laboratory at the time the Shared Laboratory Order is performed. As a result, the management of the specimen influences the Shared Laboratory Order state. The specimen has the following effect on the Shared Laboratory Order transition states:

1. The Order cannot be moved to “active” unless there is specimen information included on the Order.
2. If additional specimen is required, the Laboratory Order state can be updated to “suspended” for additional Specimen Handling. Once additional specimen information is added to the Order, testing can be resumed and the Order can be returned to the “active” state.
3. If the Laboratory Order cannot be performed at all without a new specimen the Laboratory Order is “aborted”, and the Healthcare Provider and/or Organization is informed why the Laboratory Order was aborted through comments in the Laboratory Order.
4. If the entire Laboratory Order cannot be completed without a new specimen, the requested test(s) which cannot be completed are ”aborted”, and the Healthcare Provider and/or Organization is informed why the requested test(s) were aborted through comments in the Laboratory Order. The Laboratory Order itself may be “aborted” or “completed” per the laboratory protocol.
5. If the Laboratory Order can be completed, but additional tests requiring a new Laboratory Order with a new specimen are required, the Laboratory Order is ”completed”, and the Healthcare Provider and/or Organization may be informed through comments in the Laboratory Order or the Laboratory Results Report(s).
6. If the Laboratory cannot perform the Laboratory Order and it can be transferred to another Laboratory, the original Laboratory can set the status of the Order back to “new” to be claimed by another Laboratory. (The process of re-scheduling the Laboratory Order and transferring the specimen is determined by business policy). The reason for relinquishing the Laboratory Order is documented in a comment on the Laboratory Order.

3.3 USE OF KSA-WIDE IDENTIFIERS WITHIN CODED LABORATORY ORDERS

As a part of the interoperability of sharing Coded Laboratory Orders, the Laboratory Order Creator must provide KSA-Wide identifiers rather than local identifiers and codes. One set of parameters which is critical for linking the local laboratory order and the shared Coded Laboratory Orders is the Placer Order ID. The Placer Order ID is the identifier assigned to a

laboratory order at the time of its creation. Organizations typically provide a mechanism to ensure that within the organization the Placer Order ID is unique. In order to ensure that the Placer Order ID for a shared laboratory order is unique, the KSA-Wide Organization identifier becomes a part of the Placer Order ID for a shared laboratory order (See the IS0105 *Saudi eHealth Laboratory Results and Orders Content Interoperability Specification* Section 2.1.2 for detail on KSA-Wide identifier requirements). Note that a single local laboratory order may result in multiple shared Coded Laboratory Orders because of the restriction that the shared laboratory order be limited to a single Laboratory Specialty (Department). In order to link the local laboratory order with the Shared Coded Laboratory Order(s), the Laboratory Order Creator must include the KSA-Wide Placer Order ID in the shared Laboratory Order.

3.4 LABORATORY SUB-CONTRACTING WORKFLOW

Within the Saudi eHealth System, the process of supporting laboratory sub-contracting will continue to be a process internal to the laboratory. This means that Laboratory Orders for sub-contracted laboratory work will not use Shared Laboratory Orders. Likewise, sub-contracted results report(s) will not be shareable directly. The primary laboratory will be responsible for creating Shared Results Report(s) which include the sub-contracted laboratory results.

4. CORE INTEROPERABILITY SPECIFICATION REQUIREMENTS

4.1 ACTOR MAPPING TO SAUDI EHEALTH IS SPECIFICATIONS

A system conforming to this Core Interoperability Specification shall claim conformance at the level of a Use Case Actor. The Actors and the Services they support are described at a functional level in the Saudi eHealth Interoperability Use Case document. Services may be required, conditional or optional. Multiple systems may fulfill a Use Case Actor.

The Use Case Actor, Service(s) and Optionality are conveyed in the first three columns of Interoperability Conformance Requirement tables shown below.

The second part of the table (columns 4-7) provides the mapping for the Use Case Actor to the detailed specifications (such as IHE Profiles, Technical Actors, Optionality) that systems shall implement to exchange healthcare information in the context of this Use Case.

For a selected Use Case Actor (a single row in the table), all the requirements listed in the second part of the table (columns 4-7) shall be implemented. This includes the referenced profiles and the standards specified (terminology or other). For each Technical Actor (whether required or optional), the last column references the detailed specification that constrain and extend of the implementation of this profile for KSA specific requirements. These specifications may be found in Appendices to this core specification or in other referenced KSA eHealth Interoperability Specifications (e.g. IS0101 *Saudi eHealth Security and Privacy Interoperability Specification*, etc.).

TABLE 4.1-1 INTEROPERABILITY CONFORMANCE REQUIREMENTS FOR LABORATORY ORDER CREATOR

CODED LABORATORY ORDERS			MAPPING TO TECHNICAL CONSTRUCTS OF SAUDI EHEALTH INTEROPERABILITY SPECIFICATIONS			
USE CASE ACTOR	SERVICE SUPPORTED	OPT	TECHNICAL ACTOR	OPT	PROFILE/ STANDARD	REFERENCED SPECIFICATION
Laboratory Order Creator	Publish Order	R	Content Creator	R	Health Level Seven (HL7) Clinical Document Architecture Release 2 (CDA R2)	IS0105 Saudi eHealth Laboratory Results and Orders Content Interoperability Specification - Section 3.1
			Document Source	R	IHE – Cross-Enterprise Document Sharing (XDS.b)	IS0102 Saudi eHealth Document Sharing Interoperability Specification– Section 3.2
			Secure Node	R	IHE Audit Trail and Node Authentication (ATNA)	IS0101 Saudi eHealth Security and Privacy Interoperability Specification – Section 3.2 and 3.3.2
			Time Client	R	IHE Consistent Time (CT)	IS0101 Saudi eHealth Security and Privacy Interoperability Specification – Section 3.1.2
	Query/Retrieve Order ²	R	Document Consumer	R	IHE – Cross-Enterprise Document Sharing (XDS.b)	IS0102 Saudi eHealth Document Sharing Interoperability Specification– Section 3.3
			Content Consumer	R	Health Level Seven (HL7) Clinical Document Architecture Release 2 (CDA R2)	IS0105 Saudi eHealth Laboratory Results and Orders Content Interoperability Specification - Section 3.1
			X-Service User	R	IHE – Cross-Enterprise User Assertion (XUA)	IS0101 Saudi eHealth Security and Privacy Interoperability Specification – Section 3.4.1

² The Query/Retrieve Order service is used by the Laboratory Order Creator to obtain order status updates from the Laboratory Order Fulfiller such as order completed, aborted, etc.

CODED LABORATORY ORDERS			MAPPING TO TECHNICAL CONSTRUCTS OF SAUDI EHEALTH INTEROPERABILITY SPECIFICATIONS			
USE CASE ACTOR	SERVICE SUPPORTED	OPT	TECHNICAL ACTOR	OPT	PROFILE/ STANDARD	REFERENCED SPECIFICATION
			Secure Node	R	IHE Audit Trail and Node Authentication (ATNA)	IS0101 Saudi eHealth Security and Privacy Interoperability Specification – Section 3.2 and 3.3.2
			Time Client	R	IHE Consistent Time (CT)	IS0101 Saudi eHealth Security and Privacy Interoperability Specification – Section 3.1.2
	Notification of Document Availability	O	Document Metadata Notification Recipient	R	IHE - Document Metadata Subscription (DSUB)	IS0102 Saudi eHealth Document Sharing Interoperability Specification– Section 4.2
			Secure Node	R	IHE Audit Trail and Node Authentication (ATNA)	IS0101 Saudi eHealth Security and Privacy Interoperability Specification – Section 3.2 and 3.3.2
			Time Client	R	IHE Consistent Time (CT)	IS0101 Saudi eHealth Security and Privacy Interoperability Specification – Section 3.1.2

R=Required, O = Optional, C= Conditional

TABLE 4.1-2 INTEROPERABILITY CONFORMANCE REQUIREMENTS FOR LABORATORY ORDER FULFILLER

CODED LABORATORY ORDERS			MAPPING TO TECHNICAL DOCUMENTS OF SAUDI EHEALTH INTEROPERABILITY SPECIFICATIONS			
USE CASE ACTOR	SERVICE SUPPORTED	OPT	TECHNICAL ACTOR	OPT	PROFILE/ STANDARD	REFERENCED SPECIFICATION AND COMMENTS
Laboratory Order Fulfiller	Query/Retrieve Order	R	Document Consumer	R	IHE – Cross-Enterprise Document Sharing (XDS.b)	IS0102 Saudi eHealth Document Sharing Interoperability Specification – Section 3.3

CODED LABORATORY ORDERS			MAPPING TO TECHNICAL DOCUMENTS OF SAUDI EHEALTH INTEROPERABILITY SPECIFICATIONS			
USE CASE ACTOR	SERVICE SUPPORTED	OPT	TECHNICAL ACTOR	OPT	PROFILE/ STANDARD	REFERENCED SPECIFICATION AND COMMENTS
			Content Consumer	R	Health Level Seven (HL7) Clinical Document Architecture Release 2 (CDA R2)	IS0105 Saudi eHealth Laboratory Results and Orders Content Interoperability Specification - Section 3.1
			X-Service User	R	IHE – Cross-Enterprise User Assertion (XUA)	IS0101 Saudi eHealth Security and Privacy Interoperability Specification – Section 3.4.1
			Secure Node	R	IHE Audit Trail and Node Authentication (ATNA)	IS0101 Saudi eHealth Security and Privacy Interoperability Specification – Section 3.2 and 3.3.2
			Time Client	R	IHE Consistent Time (CT)	IS0101 Saudi eHealth Security and Privacy Interoperability Specification – Section 3.1.2
	Notification of Document Availability	O	Document Metadata Notification Recipient	R	IHE - Document Metadata Subscription (DSUB)	IS0102 Saudi eHealth Document Sharing Interoperability Specification – Section 4.2
			Secure Node	R	IHE Audit Trail and Node Authentication (ATNA)	IS0101 Saudi eHealth Security and Privacy Interoperability Specification – Section 3.2
			Time Client	R	IHE Consistent Time (CT)	IS0101 Saudi eHealth Security and Privacy Interoperability Specification – Section 3.1.2
	Publish Order ³	R	Content Creator	R	Health Level Seven (HL7) Clinical Document Architecture Release 2 (CDA R2)	IS0105 Saudi eHealth Laboratory Results and Orders Content Interoperability Specification - Section 3.1

³ The Publish Order service is used by the Laboratory Order Fulfiller to provide updated order status to the Laboratory Order Creator, such as order in-process, completed, aborted, etc.

CODED LABORATORY ORDERS			MAPPING TO TECHNICAL DOCUMENTS OF SAUDI EHEALTH INTEROPERABILITY SPECIFICATIONS			
USE CASE ACTOR	SERVICE SUPPORTED	OPT	TECHNICAL ACTOR	OPT	PROFILE/ STANDARD	REFERENCED SPECIFICATION AND COMMENTS
			Document Source	R	IHE – Cross-Enterprise Document Sharing (XDS.b)	IS0102 Saudi eHealth Document Sharing Interoperability Specification – Section 3.2
			Secure Node	R	IHE Audit Trail and Node Authentication (ATNA)	IS0101 Saudi eHealth Security and Privacy Interoperability Specification – Section 3.2 and 3.3.2
			Time Client	R	IHE Consistent Time (CT)	IS0101 Saudi eHealth Security and Privacy Interoperability Specification – Section 3.1.2

R=REQUIRED, O = OPTIONAL, C= CONDITIONAL

TABLE 4.1-3 INTEROPERABILITY CONFORMANCE REQUIREMENTS FOR DOCUMENT REPOSITORY

CODED LABORATORY ORDERS			MAPPING TO TECHNICAL DOCUMENTS OF SAUDI EHEALTH INTEROPERABILITY SPECIFICATIONS			
USE CASE ACTOR	SERVICE SUPPORTED	OPT	TECHNICAL ACTOR	OPT	PROFILE/ STANDARD	REFERENCED SPECIFICATION AND COMMENTS
Document Repository	Publish Order	R	Document Repository	R	IHE – Cross-Enterprise Document Sharing (XDS.b)	IS0102 Saudi eHealth Document Sharing Interoperability Specification – Section 3.4
			Secure Node	R	IHE Audit Trail and Node Authentication (ATNA)	IS0101 Saudi eHealth Security and Privacy Interoperability Specification – Section 3.2 and 3.3.1
			Time Client	R	IHE Consistent Time (CT)	IS0101 Saudi eHealth Security and Privacy Interoperability Specification – Section 3.1.2
	Query/Retrieve Order	R	Document Registry and Document Repository	R	IHE – Cross-Enterprise Document Sharing (XDS.b)	IS0102 Saudi eHealth Document Sharing Interoperability Specification– Section 3.4

CODED LABORATORY ORDERS			MAPPING TO TECHNICAL DOCUMENTS OF SAUDI EHEALTH INTEROPERABILITY SPECIFICATIONS			
USE CASE ACTOR	SERVICE SUPPORTED	OPT	TECHNICAL ACTOR	OPT	PROFILE/ STANDARD	REFERENCED SPECIFICATION AND COMMENTS
			X-Service Provider	R	IHE – Cross-Enterprise User Assertion (XUA)	IS0101 Saudi eHealth Security and Privacy Interoperability Specification – Section 3.4.2
			Secure Node	R	IHE Audit Trail and Node Authentication (ATNA)	IS0101 Saudi eHealth Security and Privacy Interoperability Specification – Section 3.2 and 3.3.1
			Time Client	R	IHE Consistent Time (CT)	IS0101 Saudi eHealth Security and Privacy Interoperability Specification – Section 3.1.2
	Notification of Document Availability	R	Document Metadata Notification Broker	R	IHE - Document Metadata Subscription (DSUB)	IS0102 Saudi eHealth Document Sharing Interoperability Specification– Section 4.1
			Secure Node	R	IHE Audit Trail and Node Authentication (ATNA)	IS0101 Saudi eHealth Security and Privacy Interoperability Specification – Section 3.2 and 3.3.1
			Time Client	R	IHE Consistent Time (CT)	IS0101 Saudi eHealth Security and Privacy Interoperability Specification – Section 3.1.2

R=Required, O = Optional, C= Conditional

4.2 INTEROPERABILITY SEQUENCE DIAGRAMS

The following Sequence diagrams provide an overview of the combined flow of transactions resulting from the above selected profiles and standards. The Main Flow Sequence Diagram illustrates a very common (i.e., typical) workflow and other sequence diagrams are shown to provide an alternative to the main flow. Other sequence diagrams are possible but they cover the same key transactions with only slight variants of information exchange between the System Components, and therefore, are not shown. For more information of possible workflow scenarios see Section 2.3.

The Coded Laboratory Order sequence diagrams provide a high-level sequence of events for the exchange of information for sharing a patient’s Laboratory Order. It also illustrates typical security exchanges for authorized network communications and audit trail of patient information access. The sequence diagrams show only transactions that operate across business actors.

Transactions that operate between actors within business actors are omitted for brevity. For a complete outline of the transactions necessary for implementation of the Specification, consult tables Table 4.1-1, Table 4.1-2 and Table 4.1-3.

4.2.1 Main Flow Sequence Diagram

The main flow sequence diagram illustrates a scenario where a Healthcare Provider (e.g. in a Primary Health Care [PHC] or hospital) creates a Laboratory Order and the laboratory (e.g. regional lab, hospital lab, etc.) retrieves the Laboratory Order for processing. This figure depicts a number of transactions between IHE Profile Actors specified in the tables in Section 4.1.

Note: The Use Case Services are implemented using the underlying transaction(s) defined by the Profiles or Standards selected. Therefore, the Use Case Services are not depicted directly in the sequence diagrams.

Steps 1 – 5 are shown in Figure 4.2-1: Coded Laboratory Orders Sequence Diagram (1).

1. Time synchronization occurs independently. These transactions may take place at any time and are shown at the beginning of the sequence diagram [IHE CT Profile: Maintain Time ITI-1].
2. The patient visits a Healthcare Provider and/or Organization and the laboratory test(s) ordered cannot be performed locally. The information system determines the Laboratory Order needs to be shared with the Document Repository. A Laboratory Order Document is created as specified in IS0105 *Saudi eHealth Laboratory Results and Orders Content Interoperability Specification*. Before the exchange can take place, an authentication process takes place between the Document Source/Secure Node Actor and the Document Repository/Secure Node Actor occurs [IHE ATNA Profile: Authenticate Node ITI-19].

Note: The requirements on how to obtain a patient's KSA-Wide Health ID and key patient demographics are defined in IS0001 *Saudi eHealth Core Interoperability Specification for KSA-Wide Patient Demographic Query*. The Health ID and key patient demographics attributes are used to identify the patient for which the laboratory reports are shared. This ensures KSA-Wide identification of the patient in health records. This is not shown as the diagram and details to accomplish this are defined in IS0001 *Saudi eHealth Core Interoperability Specification for KSA-Wide Patient Demographic Query*.

3. Following node authentication, the Document Source transmits the Laboratory Order document to Document Repository. [IHE XDS.b Profile: Provide and Register Document Set – b ITI-41]. The format of the Laboratory Order document is defined by [HL7 CDA R2]. The Document Repository stores the Laboratory Order document.
4. The Document Repository registers the Laboratory Order document with the Document Registry [IHE XDS.b: Register Document Set – b ITI-42].

Note: The IHE XDS.b: [Register Document Set – b ITI-42] transaction is listed without first performing the authentication between the two systems [IHE ATNA Profile: Authenticate Node ITI-19]. This is because it is very common that the Document Repository and Registry are implemented within the same system. If these Actors are implemented in separate systems the authentication transaction would be required.

- The Document Source/Secure Node generates a local audit record of the access to patient health information [using the data content as defined by IHE ATNA Profile and Section 5.1] and the Document Repository/Secure Node generates an audit record of the receipt of patient health information [IHE ATNA Profile: Record Audit Event ITI-20].

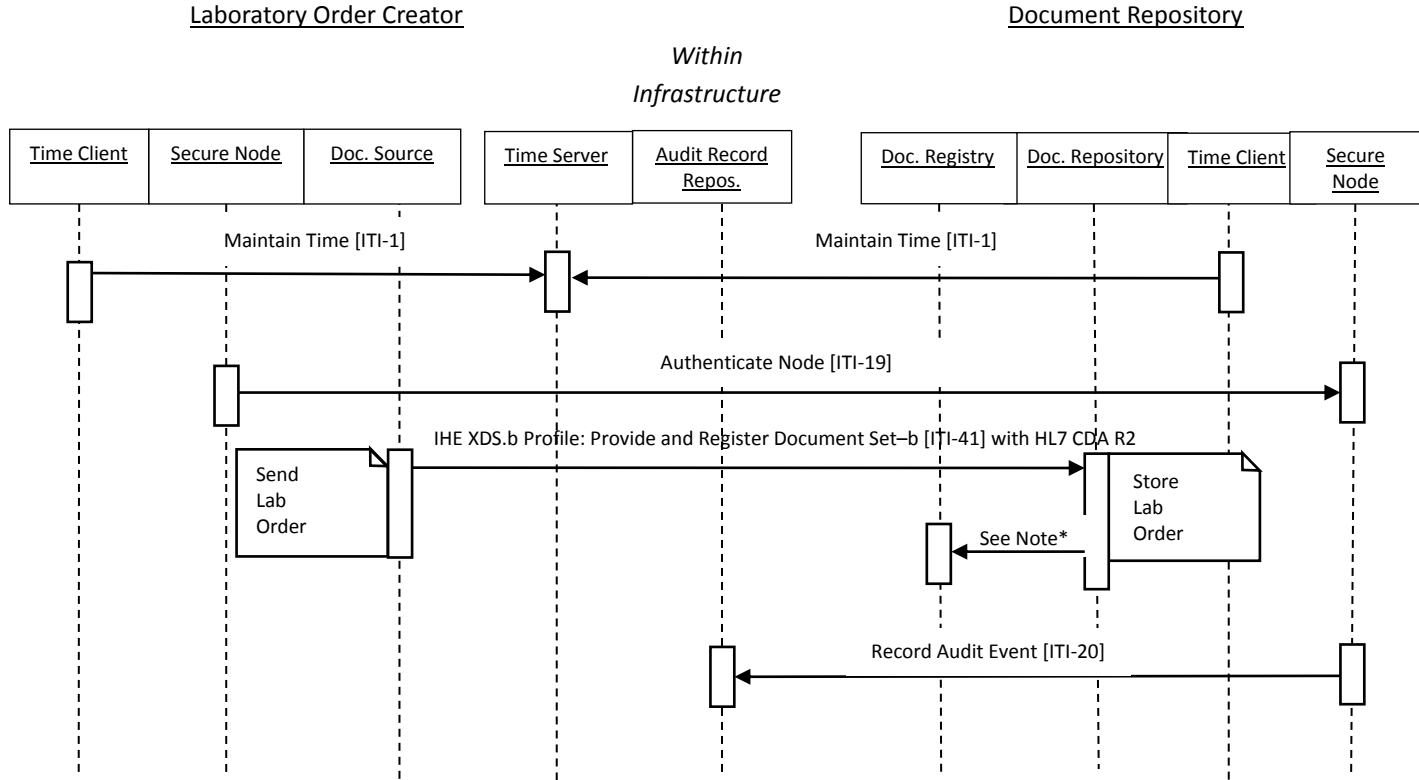

FIGURE 4.2-1: CODED LABORATORY ORDERS SEQUENCE DIAGRAM (1)

Steps 6 – 22 related to access to coded Laboratory Orders are shown in

Note: Time Client and Time Server Actors have been omitted due to limited space on the diagram. The systems need to perform on-going time synchronization [IHE CT Profile: Maintain Time ITI-1] as shown in Step 1.

- The patient arrives at the laboratory and using the patient’s KSA-Wide Health ID, the supporting system queries the Document Registry to determine if Laboratory Order is available. Before the information exchange can take place, an authentication process between the Document Consumer/Secure Node Actor and the Document Registry/Secure Node Actor takes place [IHE ATNA Profile: Authenticate Node ITI-19].

7. The Document Consumer/X-Service User queries the Document Registry/X-Service Provider to determine if the patient's Laboratory Order is available⁴. As part of the query request, a user assertion is conveyed to verify that the laboratory technician is an authorized user to obtain patient information is performed [IHE XDS-b: Registry Stored Query ITI-18] and [IHE XUA: Provide X-User Assertion ITI-40].
8. The Document Consumer/Secure Node generates a local audit record of the access to patient health information [using the data content as defined by IHE ATNA Profile and Section 5.1].
9. The Document Registry processes the query and responds with the information needed to retrieve the Laboratory Order [IHE XDS-b: Registry Stored Query ITI-18].
10. The Document Registry/Secure Node generates an audit record of the access to patient health information [IHE ATNA Profile: Record Audit Event ITI-20].
11. The laboratory technician uses the Document Consumer to retrieve the Laboratory Order. Before the information exchange can take place, another authentication process between the Document Consumer /Secure Node Actor and the Document Repository/Secure Node Actor takes place [IHE ATNA Profile: Authenticate Node ITI-19].
12. The Document Consumer/X-Service User retrieves the Laboratory Order. As part of the retrieve, a user assertion is conveyed to verify that the technician is an authorized user to obtain patient information is performed [IHE XDS-b: Retrieve Document Set ITI-43] and [IHE XUA: Provide X-User Assertion ITI-40].
13. The Document Repository/Secure Node generates an audit record of the access to patient health information [IHE ATNA Profile: Record Audit Event ITI-20].
14. The coded Laboratory Order is available for the laboratory technician to process. The technician updates the Laboratory Order status to "active" (Laboratory Order in-process). The Laboratory Order Fulfiller shares the updated Laboratory Order with the Document Repository. Before the exchange can take place, an authentication process takes place between the Document Source/Secure Node Actor and the Document Repository/Secure Node Actor occurs [IHE ATNA Profile: Authenticate Node ITI-19] (the laboratory test center becomes the Document Source).
15. Following node authentication, the Document Source transmits the Laboratory Order to Document Repository with the status of ACTIVE. [IHE XDS.b Profile: Provide and Register Document Set – b ITI-41]. The format of the Laboratory Order document is defined by [HL7 CDA R2]. The Document Repository stores the Laboratory Order document.
16. The Document Repository registers the Laboratory Order document with the Document Registry [IHE XDS.b: Register Document Set – b ITI-42].

⁴ The process of creating a new Laboratory Order if one does not exist for the patient is out of scope for this Interoperability Specification. However, the options are: that a Laboratory Order be created locally, that a Shared Laboratory Order be created by the laboratory or that a Shared Laboratory Order be created by the ordering health provider or organization.

Note: The IHE XDS.b: [Register Document Set – b ITI-42] transaction is listed without first performing the authentication between the two systems [IHE ATNA Profile: Authenticate Node ITI-19]. This is because it is very common that the Document Repository and Registry are implemented within the same systems. If these Actors are implemented in separate systems the authentication transaction would be required.

17. The Document Source/Secure Node generates a local audit record of the release to patient health information [using the data content as defined by IHE ATNA Profile and Section 5.1] and the Document Repository/Secure Node generates an audit record of the receipt of patient health information [IHE ATNA Profile: Record Audit Event ITI-20].
18. The laboratory technician generates one or more Laboratory Results Reports (based upon the requirements of the order) and stores them upon the Document Repository [IHE XDS.b Profile: Provide and Register Document Set – b ITI-41]
19. The laboratory technician updates the Laboratory Order to “completed”. The Laboratory Order Fulfiler shares the Laboratory Order document with the Document Repository. Before the exchange can take place, an authentication process takes place between the Document Source/Secure Node Actor and the Document Repository/Secure Node Actor occurs [IHE ATNA Profile: Authenticate Node ITI-19] (the laboratory test center becomes the Document Source).

Note: The creation and management of the laboratory test results is defined in IS0003 *Saudi eHealth Core Interoperability Specification for Sharing Coded Laboratory Results*. It is not documented in this Core Interoperability Specification.

20. Following node authentication, the Document Source transmits the Laboratory Order to Document Repository with the status of “completed”. [IHE XDS.b Profile: Provide and Register Document Set – b ITI-41]. The format of the Laboratory Order document is defined by [HL7 CDA R2]. The Document Repository stores the Laboratory Order document.
21. The Document Repository registers the Laboratory Order with the Document Registry [IHE XDS.b: Register Document Set – b ITI-42].

Note: The IHE XDS.b: [Register Document Set – b ITI-42] transaction is listed without first performing the authentication between the two systems [IHE ATNA Profile: Authenticate Node ITI-19]. This is because it is very common that the Document Repository and Registry are implemented within the same systems. If these Actors are implemented in separate systems the authentication transaction would be required.

22. The Document Source/Secure Node generates a local audit record of the release of patient health information [using the data content as defined by IHE ATNA Profile and Section 5.1] and the Document Repository/Secure Node generates an audit record of the receipt of patient health information [IHE ATNA Profile: Record Audit Event ITI-20].

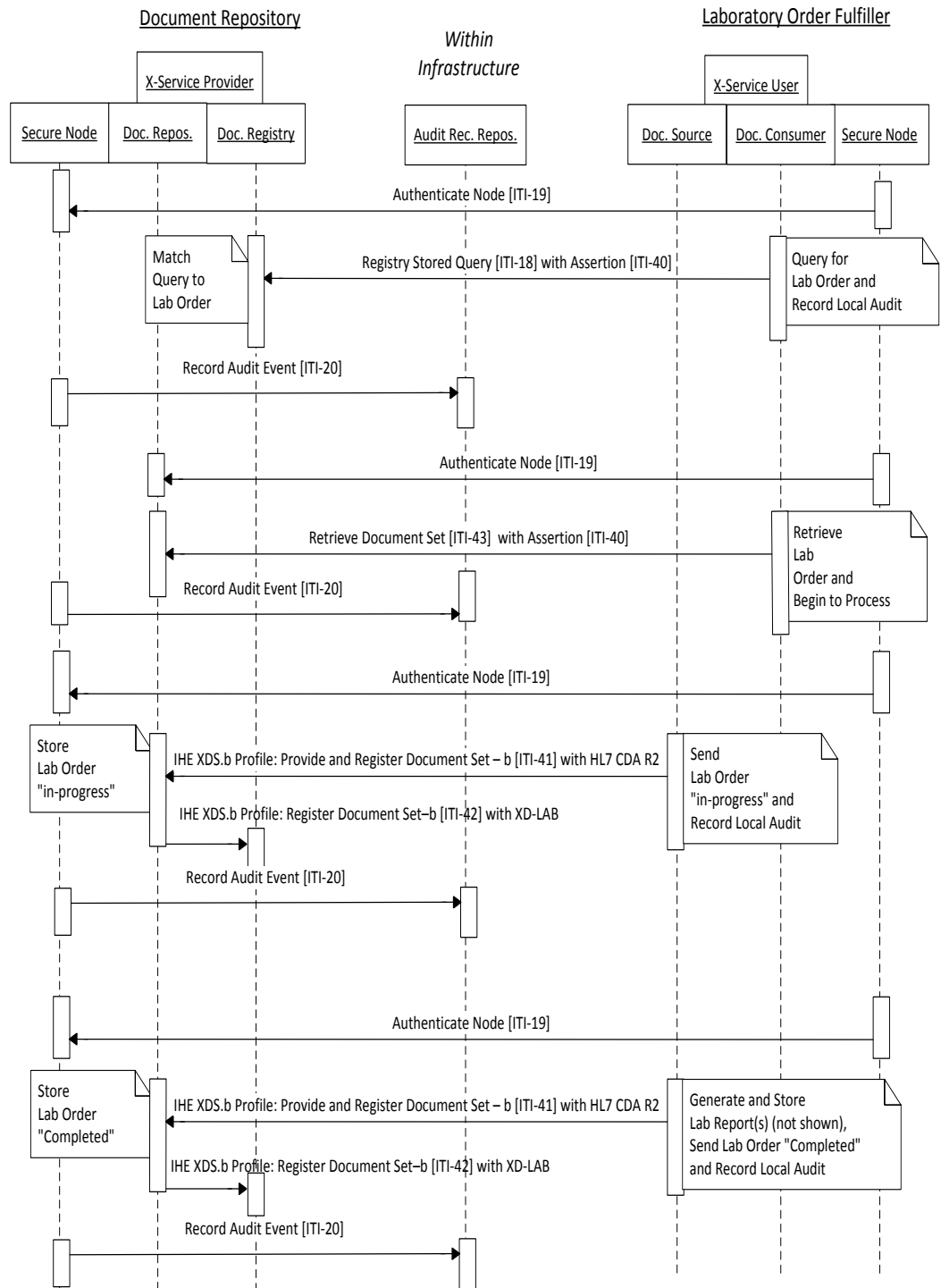

FIGURE 4.2-2 CODED LABORATORY ORDER SEQUENCE DIAGRAM (2)

Steps 23 – 28 related to access to Coded Laboratory Orders are shown in Figure 4.2-3 Coded Laboratory Order Sequence Diagram (3).

Note: Time Client and Time Server Actors have been omitted due to limited space on the diagram. The systems need to perform on-going time synchronization [IHE CT Profile: Maintain Time ITI-1] as shown in Step 1.

23. The Healthcare Provider uses its supporting system to query the Document Registry to determine if Laboratory Order has been updated to the status of “completed” (or any other status). Before the information exchange can take place, an authentication process between the Document Consumer/Secure Node Actor and the Document Registry/Secure Node Actor takes place [IHE ATNA Profile: Authenticate Node ITI-19] (the ordering systems is now the Document Consumer).
24. The Document Consumer/X-Service User queries the Document Registry/X-Service Provider to determine if the patient’s Laboratory Order status has been updated. As part of the query request, a user assertion is conveyed to verify that the Healthcare Provider is an authorized user to obtain patient information is performed [IHE XDS-b: Registry Stored Query ITI-18] and [IHE XUA: Provide X-User Assertion ITI-40].
25. The Document Consumer/Secure Node generates a local audit record of the access to patient health information [using the data content as defined by IHE ATNA Profile and Section 5.1]and the Document Repository/Secure Node generates an audit record of the access to patient health information [IHE ATNA Profile: Record Audit Event ITI-20].
26. The Document Registry processes the query and responds with the information that the Laboratory Order is completed [IHE XDS-b: Registry Stored Query ITI-18].
27. The Document Registry/Secure Node generates an audit record of the access to patient health information [IHE ATNA Profile: Record Audit Event ITI-20].
28. The Healthcare Provider learns the order is completed and retrieves all associated Laboratory Results Reports for the patient and provides follow up care.

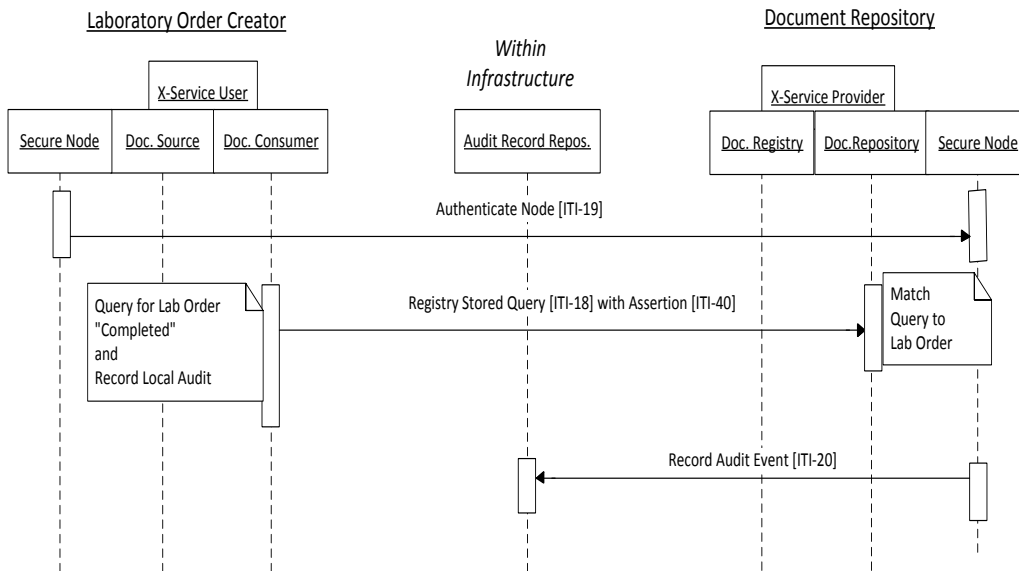

FIGURE 4.2-3 CODED LABORATORY ORDER SEQUENCE DIAGRAM (3)

4.2.2 Cancel Order Sequence Diagram

The cancel order sequence diagram is for the scenario when a Laboratory Order has been cancelled by the ordering Healthcare Provider or Organization. The main flow sequence diagram is a pre-condition as the original Laboratory Order must be created before being cancelled (the original order creation is not repeated in this diagram). See Section 4 for more details on status state transitions. This figure depicts a number of transactions between IHE Profile Actors specified in the multiple tables in Section 4.1.

Steps 1 – 5 are shown in Figure 4.2-4 Cancelled Order Sequence Diagram (1)

1. Time synchronization is not shown but occurs as shown in other diagrams [IHE CT Profile: Maintain Time ITI-1].
2. The ordering Healthcare Provider that created the original order decides to cancel the patient's Laboratory Order (i.e. change of condition for the patient). The Healthcare Provider cancels the order in the Ordering System. The Ordering System shares the cancelled Laboratory Order with the Document Repository. Before this can take place, an authentication process between the Document Source/Secure Node Actor and the Document Repository/Secure Node Actor occurs [IHE ATNA Profile: Authenticate Node ITI-19].

Note: When the cancelled Laboratory Order is published, the source system informs the Document Repository that it is a replacement to the original, previously shared document. This information is used by the Document Repository to manage the two versions (i.e. cancel the original order and provide a link between the original/cancelled order). (See IS0102 *Saudi*

eHealth Document Sharing Interoperability Specification for additional details on document deprecation).

3. Following node authentication, the cancelled Laboratory Order document is transmitted [IHE XDS.b: Profile: Provide and Register Document Set – b ITI-41]. The format of the report is defined by [HL7 CDA R2]. The Document Repository stores the cancelled order and deprecates the original Laboratory Order.
4. The Document Repository registers the cancelled Laboratory Order with the Document Registry [IHE XDS.b: Register Document Set – b ITI-42].

Note: The IHE XDS.b: [Register Document Set – b ITI-42] transaction is listed without first performing the authentication between the two systems [IHE ATNA Profile: Authenticate Node ITI-19]. This is because it is very common that the Document Repository and Registry are implemented within the same systems. If these Actors are implemented in separate systems the authentication transaction would be required.

5. The Document Source generates a local audit record of the release of patient health information [using the data content as defined by IHE ATNA Profile and Section 5.1] and the Document Repository/Secure Node generates an audit record of the receipt of patient health information [IHE ATNA Profile: Record Audit Event ITI-20].

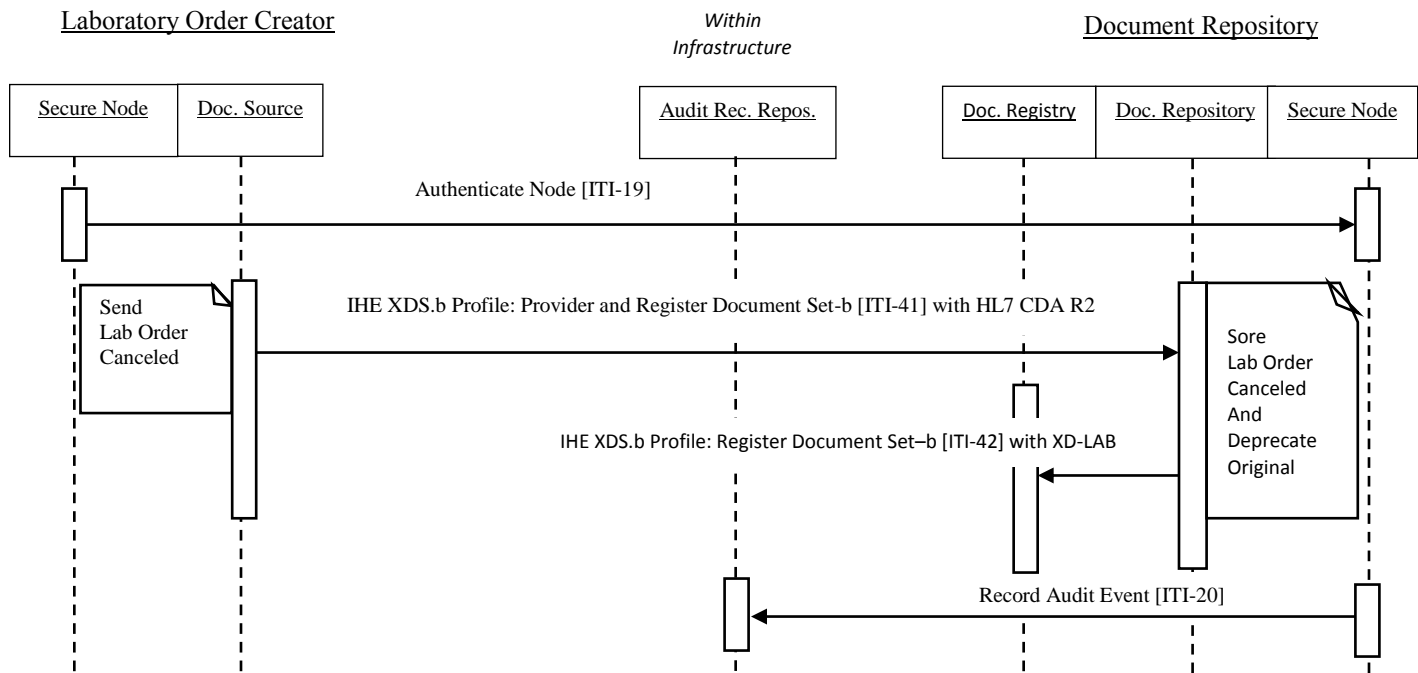

FIGURE 4.2-4 CANCELLED ORDER SEQUENCE DIAGRAM (1)

Steps 6 – 14 related to access to Coded Laboratory Orders are shown in Figure 4.2-5 Cancelled Order Sequence Diagram (2).

Note: Time Client and Time Server Actors have been omitted due to limited space on the diagram. The systems need to perform on-going time synchronization [IHE CT Profile: Maintain Time ITI-1] as shown in Step 1.

6. The patient arrives at the laboratory and using the patient's KSA-Wide Health ID. The supporting system queries the Document Registry to determine if Laboratory Order is available. Before the information exchange can take place, an authentication process between the Document Consumer/Secure Node Actor and the Document Registry/Secure Node Actor takes place [IHE ATNA Profile: Authenticate Node ITI-19].
7. The Document Consumer/X-Service User queries the Document Registry/X-Service Provider to determine if the patient's Laboratory Order is available. As part of the query request, a user assertion is conveyed to verify that the technician is an authorized user to obtain patient information is performed [IHE XDS-b: Registry Stored Query ITI-18] and [IHE XUA: Provide X-User Assertion ITI-40].
8. [DELETED]
9. The Document Registry processes the query and responds with the information needed to retrieve the Laboratory Order document [IHE XDS-b: Registry Stored Query ITI-18].
10. The Document Registry/Secure Node generates an audit record of the access to patient health information [IHE ATNA Profile: Record Audit Event ITI-20].
11. The technician uses the Document Consumer to retrieve the Laboratory Order document. Before the information exchange can take place, another authentication process between the Document Consumer /Secure Node Actor and the Document Repository/Secure Node Actor takes place [IHE ATNA Profile: Authenticate Node ITI-19].
12. The Document Consumer/X-Service User retrieves the Laboratory Order. As part of the retrieve, a user assertion is conveyed to verify that the technician is an authorized user to obtain patient information is performed [IHE XDS-b: Retrieve Document Set ITI-43] and [IHE XUA: Provide X-User Assertion ITI-40].
13. The Document Repository/Secure Node generates an audit record of the access to patient health information [IHE ATNA Profile: Record Audit Event ITI-20].
14. The laboratory technician reviews the Coded Laboratory Order and has determined it has been cancelled. Following laboratory protocol no testing is performed.

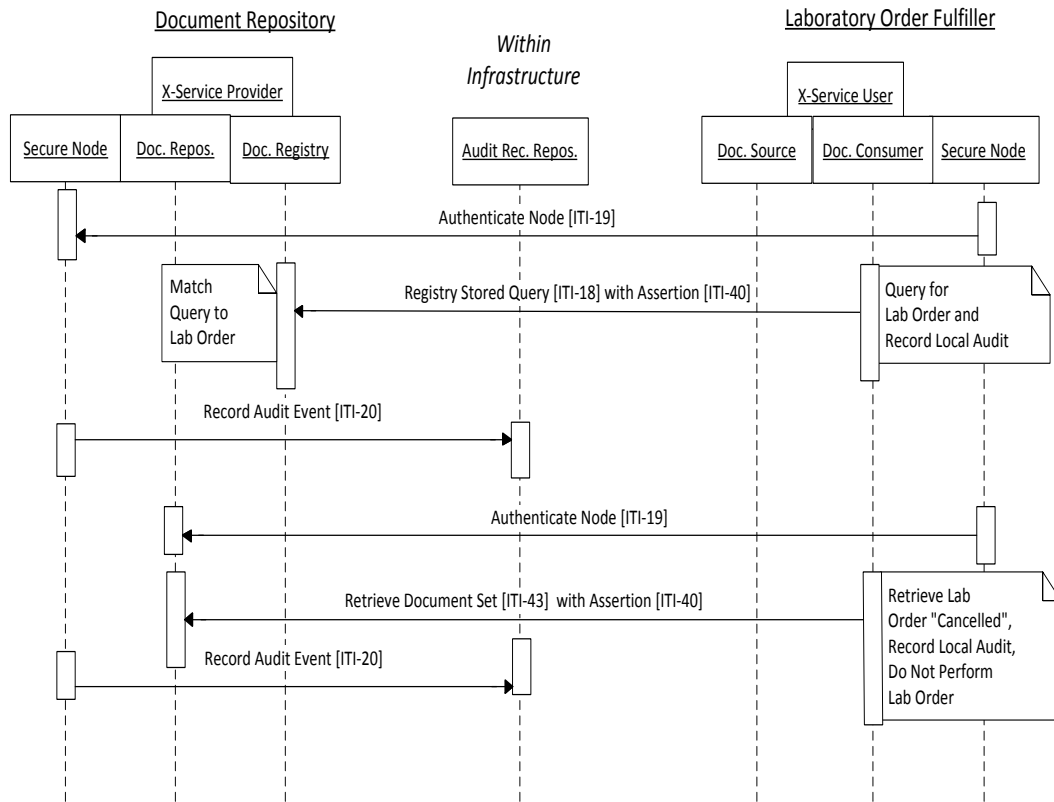

FIGURE 4.2-5 CANCELLED ORDER SEQUENCE DIAGRAM (2)

4.2.3 Laboratory - Abort Order Sequence Diagram

The laboratory technician retrieves the Shared Laboratory Order from the Document Repository using the Laboratory Order Fulfiller and matches the sample to the patient's Laboratory Order. The laboratory technician determines the specimen (e.g. blood sample) is inappropriate to perform the requested test(s). Using the Laboratory Order Fulfiller, the laboratory technician adds a comment to the Laboratory Order and updates the Laboratory Order Status to "aborted", and sends the updated Laboratory Order document to the Document Repository. The Document Repository sends a notification to the ordering Healthcare Provider or Organization. The original Laboratory Order Creator retrieves the order and processes the "aborted" status.

The main flow sequence diagram is a pre-condition as the original Laboratory Order must be created and retrieved by the laboratory (the sequence diagram is not repeated in this diagram). This figure depicts a number of transactions between IHE Profile Actors specified in the tables in Section 2.1.

Steps 1 – 5 are shown in Figure 4.2-6 Laboratory– Abort Order (with notification) Sequence Diagram (1).

1. Time synchronization is not shown but occurs as shown in other diagrams [IHE CT Profile: Maintain Time ITI-1].
2. The laboratory technician determined the specimen (e.g. blood sample) is inappropriate to perform the requested test(s) and using the Laboratory Order Fulfiller “aborts” the Laboratory Order. Now acting as a Document Source, the Laboratory Order Fulfiller shares the aborted Laboratory Order with the Document Repository. Before this can take place, an authentication process between the Document Source/Secure Node Actor and the Document Repository/Secure Node Actor occurs [IHE ATNA Profile: Authenticate Node ITI-19].

Note: When the aborted Laboratory Order is published, the Laboratory Order Fulfiller informs the Document Repository that it is a replacement to the original, a previously shared document. This information is used by the Document Repository to manage the two versions (i.e. discontinue the original order and provide a link between the original/aborted order). (See IS0102 *Saudi eHealth Document Sharing Interoperability Specification* for details).

3. Following node authentication, the aborted Laboratory Order is transmitted [IHE XDS.b: Profile: Provide and Register Document Set – b ITI-41]. The format of the Laboratory Order document is defined by [HL7 CDA R2]. The Document Repository stores the aborted order and deprecates the original Laboratory Order.
4. The Document Repository registers the cancelled Laboratory Order with the Document Registry [IHE XDS.b: Register Document Set – b ITI-42].

Note: The IHE XDS.b: [Register Document Set – b ITI-42] transaction is listed without first performing the authentication between the two systems [IHE ATNA Profile: Authenticate Node ITI-19]. This is because it is very common that the Document Repository and Registry are implemented within the same systems. If these Actors are implemented in separate systems the authentication transaction would be required.

5. The Document Source generates a local audit record of the release of patient health information [using the data content as defined by IHE ATNA Profile and Section 5.1] and the Document Repository/Secure Node generates an audit record of the receipt of patient health information [IHE ATNA Profile: Record Audit Event ITI-20].

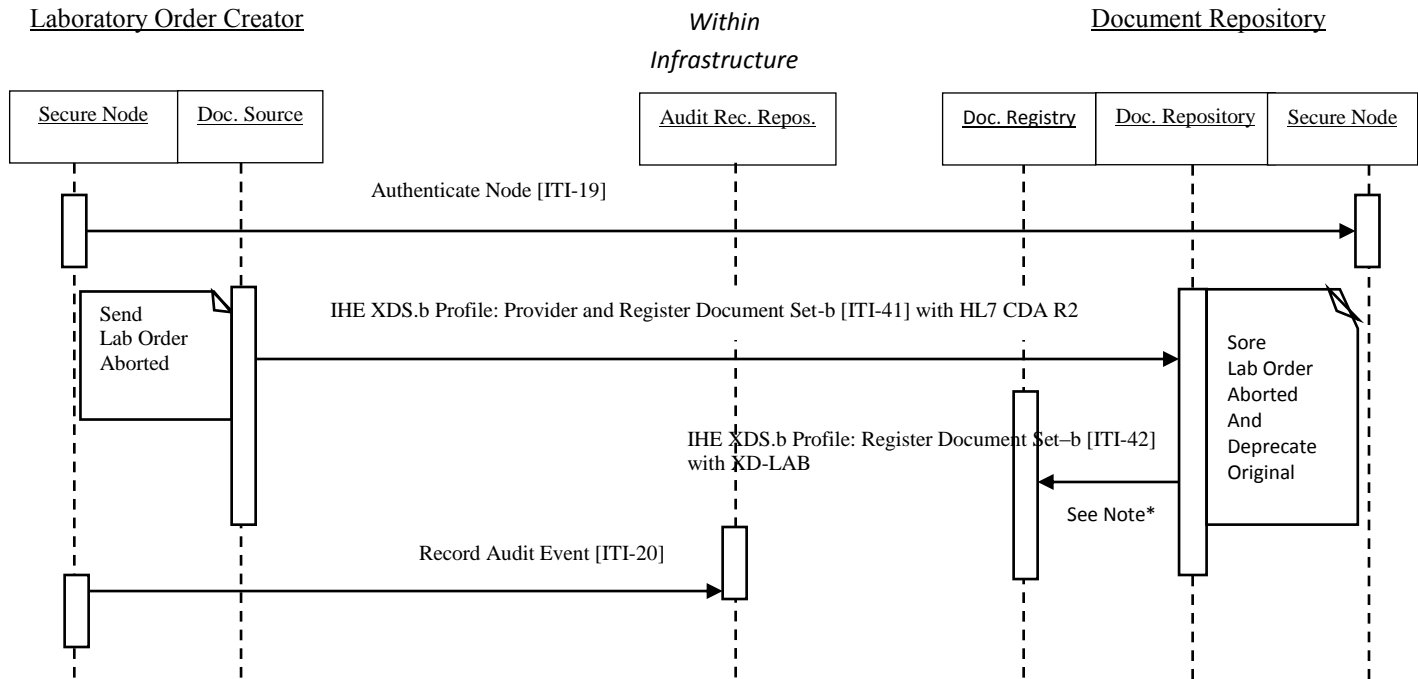

FIGURE 4.2-6 LABORATORY- ABORT ORDER (WITH NOTIFICATION) SEQUENCE DIAGRAM (1)

Steps 6 – 12 are shown in **Error! Reference source not found.**

6. The Document Repository/Document Metadata Notification Broker notifies the receiving system that the originally created the Laboratory Order has been updated with a Laboratory Order document with a status of “aborted”. The original system that created the order now acts as a Document Consumer. Before the information exchange can take place, an authentication process between the Document Repository/Document Metadata Notification Broker/Secure Node Actor and the Document Consumer/Document Metadata Notification Recipient/Secure Node Actor occurs [IHE ATNA Profile: Authenticate Node ITI-19].
7. Following node authentication, the notification of document availability is transmitted [IHE DSUB Profile: Document Metadata Notify ITI-53]. The Document Consumer has been notified that an updated order document exists (with status “aborted”).
8. The Document Repository generates an audit record of the access to patient health information [IHE ATNA Profile: Record Audit Event ITI-20].
9. Upon the successful transmission of the notification, the receiving system uses the Document Consumer Actor to retrieve the updated Laboratory Order document. Before the information exchange can take place, an authentication process between the Document Consumer /Secure Node Actor and the Document Repository/Secure Node Actor takes place [IHE ATNA Profile: Authenticate Node ITI-19].
10. The Document Consumer/X-Service User retrieves the updated Laboratory Order document. As part of the retrieve, an assertion process to verify that the technician is an

authorized user to obtain patient information is performed [IHE XDS.b: Retrieve Document Set ITI-43] and [IHE XUA: Provide X-User Assertion ITI-40].

11. The Document Repository/Secure Node generates an audit record of the access to patient health information [IHE ATNA Profile: Record Audit Event ITI-20] and the Document Consumer/Secure Node generates a local audit record of the access to patient health information [using the data content as defined by IHE ATNA Profile and Section 5.1]
12. The technician reviews the updated order with the aborted status and processes the status.

Note: The IHE XDS.b: [Register Document Set – b ITI-42] transaction is listed without first performing the authentication between the two systems [IHE ATNA Profile: Authenticate Node ITI-19]. This is because it is very common that the Document Repository and Registry are implemented within the same systems. If these Actors are implemented in separate systems the authentication transaction would be required.

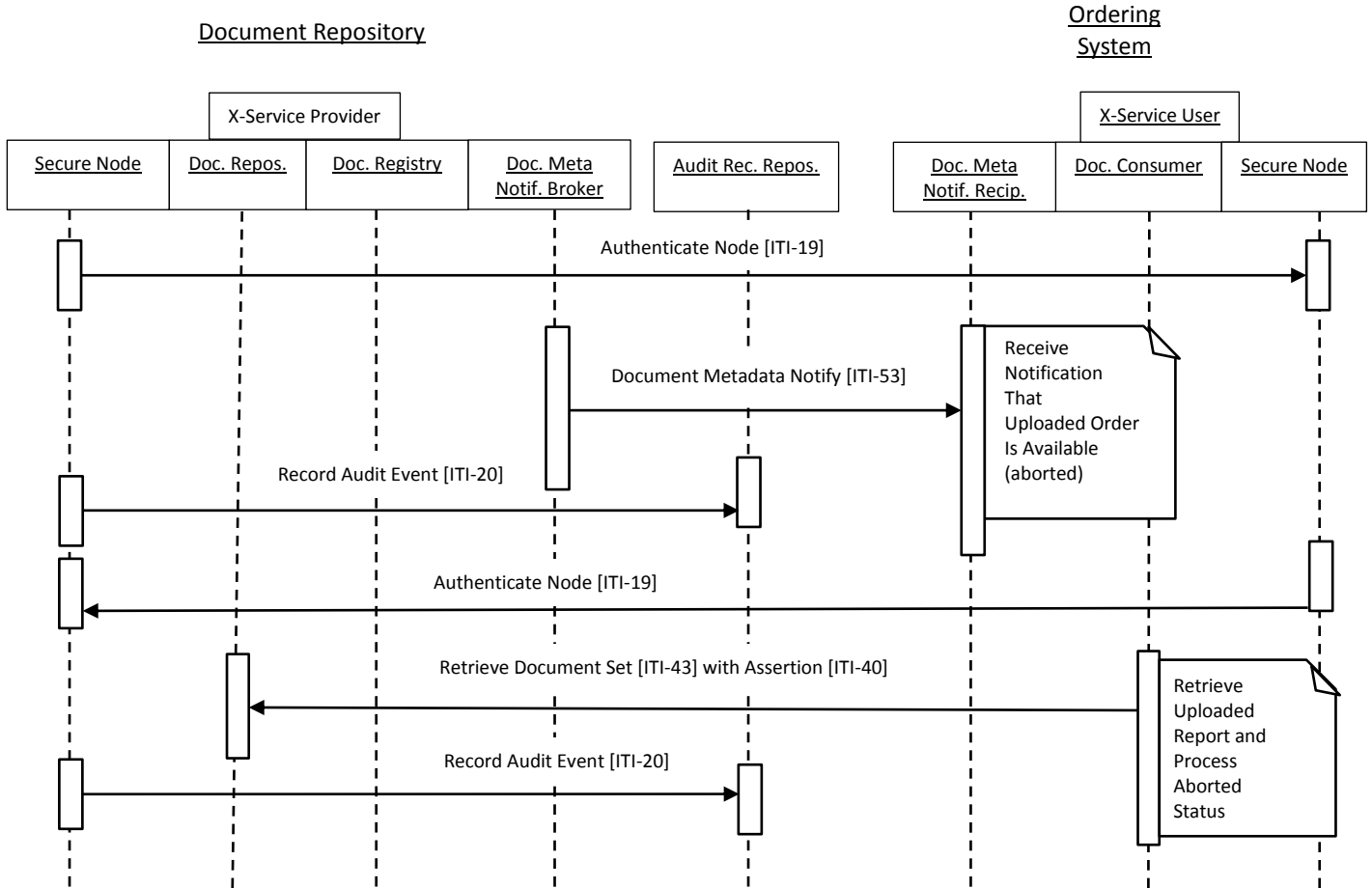

FIGURE 4.2-7 LABORATORY- ABORTED ORDER (WITH NOTIFICATION) SEQUENCE DIAGRAM (2)

5. CONFORMANCE REQUIREMENTS

5.1 LABORATORY ORDER CREATOR CONFORMANCE

Systems may claim conformance to IS0004 *Saudi eHealth Core Interoperability Specification for Coded Laboratory Orders* as a Laboratory Order Creator as follows:

“Creation of a Coded Laboratory Order as a Laboratory Creator Actor”

This requires:

- to support the Publish Document(s) Service by conforming to:
 - [CLO-001] - Health Level Seven (HL7) Clinical Document Architecture Release 2 (CDA R2) as a Content Creator Actor with the additional constraints specified in:
 - IS0105 *Saudi eHealth Laboratory Results and Orders Content Interoperability Specification* - Section 3.1
 - [CLO-002] - IHE – Cross-Enterprise Document Sharing (XDS.b) Integration Profile as a Document Source Actor with the additional constraints specified in:
 - IS0102 *Saudi eHealth Document Sharing Interoperability Specification* – Section 3.2
 - [CLO-003] - IHE Audit Trail and Node Authentication (ATNA) Integration Profile as a Secure Node Actor with the additional constraints specified in:
 - IS0101 *Saudi eHealth Security and Privacy Interoperability Specification* – Section 3.2 and 3.3.2
 - [CLO-004] – IHE Consistent Time (CT) Integration Profile as a Time Client Actor with the additional constraints specified in:
 - IS0101 *Saudi eHealth Security and Privacy Interoperability Specification* – Section 3.1.2
- To support the Query/Retrieve Document(s) Service by conforming to:
 - [CLO-005]- IHE – Cross-Enterprise Document Sharing (XDS.b) Integration Profile as a Document Consumer Actor with the additional constraints specified in:
 - IS0102 *Saudi eHealth Document Sharing Interoperability Specification* – Section 3.3
 - [CLO-006] - Health Level Seven (HL7) Clinical Document Architecture Release 2 (CDA R2) as an Content Consumer with the additional constraints specified in:
 - IS0105 *Saudi eHealth Laboratory Results and Orders Content Interoperability Specification* - Section 3.1
 - [CLO-007] - IHE – Cross-Enterprise User Assertion (XUA) Integration Profile as a X-Service User Actor with the additional constraints specified in:
 - IS0101 *Saudi eHealth Security and Privacy Interoperability Specification* – Section 3.4.1

- [CLO-008] - IHE Audit Trail and Node Authentication (ATNA) Integration Profile as a Secure Node Actor with the additional constraints specified in:
 - IS0101 *Saudi eHealth Security and Privacy Interoperability Specification* – Section 3.2 and 3.3.2
- [CLO-009] – IHE Consistent Time (CT) Integration Profile as a Time Client Actor with the additional constraints specified in:
 - IS0101 *Saudi eHealth Security and Privacy Interoperability Specification* – Section 3.1.2
- To optionally support the Notification of Document Availability Service by conforming to:
 - [CLO-010] – IHE - Document Metadata Subscription (DSUB) Integration Profile as a Document Metadata Notification Recipient Actor with the additional constraints specified in:
 - IS0102 *Saudi eHealth Document Sharing Interoperability Specification* – Section 4.2
 - [CLO-011] - IHE Audit Trail and Node Authentication (ATNA) Integration Profile as a Secure Node Actor with the additional constraints specified in:
 - IS0101 *Saudi eHealth Security and Privacy Interoperability Specification* – Section 3.2 and 3.3.2
 - [CLO-012] – IHE Consistent Time (CT) Integration Profile as a Time Client Actor with the additional constraints specified in:
 - IS0101 *Saudi eHealth Security and Privacy Interoperability Specification* – Section 3.1.2

5.2 LABORATORY ORDER FULFILLER CONFORMANCE

Systems may claim conformance to IS0004 *Saudi eHealth Core Interoperability Specification for Coded Laboratory Orders* as a Laboratory Order Fulfiller as follows:

“Fulfilling a Coded Laboratory Order as a Laboratory Order Fulfiller Actor”

This requires:

- To support the Query/Retrieve Document(s) Service by conforming to:
 - [CLO-013]- IHE – Cross-Enterprise Document Sharing (XDS.b) Integration Profile as a Document Consumer Actor with the additional constraints specified in:
 - IS0102 *Saudi eHealth Document Sharing Interoperability Specification* – Section 3.3
 - [CLO-014] - Health Level Seven (HL7) Clinical Document Architecture Release 2 (CDA R2) as an Content Consumer with the additional constraints specified in:

- IS0105 *Saudi eHealth Laboratory Results and Orders Content Interoperability Specification* - Section 3.1
- [CLO-015] - IHE – Cross-Enterprise User Assertion (XUA) Integration Profile as a X-Service User Actor with the additional constraints specified in:
 - IS0101 *Saudi eHealth Security and Privacy Interoperability Specification* – Section 3.4.1
- [CLO-016] - IHE Audit Trail and Node Authentication (ATNA) Integration Profile as a Secure Node Actor with the additional constraints specified in:
 - IS0101 *Saudi eHealth Security and Privacy Interoperability Specification* – Section 3.2 and 3.3.2
- [CLO-017] – IHE Consistent Time (CT) Integration Profile as a Time Client Actor with the additional constraints specified in:
 - IS0101 *Saudi eHealth Security and Privacy Interoperability Specification* – Section 3.1.2
- To optionally support the Notification of Document Availability Service by conforming to:
 - [CLO-018] – IHE - Document Metadata Subscription (DSUB) Integration Profile as a Document Metadata Notification Recipient Actor with the additional constraints specified in:
 - IS0102 *Saudi eHealth Document Sharing Interoperability Specification* – Section 4.2
 - [CLO-019] - IHE Audit Trail and Node Authentication (ATNA) Integration Profile as a Secure Node Actor with the additional constraints specified in:
 - IS0101 *Saudi eHealth Security and Privacy Interoperability Specification* – Section 3.2 and 3.3.2
 - [CLO-020] – IHE Consistent Time (CT) Integration Profile as a Time Client Actor with the additional constraints specified in:
 - IS0101 *Saudi eHealth Security and Privacy Interoperability Specification* – Section 3.1.2
- to support the Publish Document(s) Service by conforming to:
 - [CLO-021] - Health Level Seven (HL7) Clinical Document Architecture Release 2 (CDA R2) as a Content Creator Actor with the additional constraints specified in:
 - IS0105 *Saudi eHealth Laboratory Results and Orders Content Interoperability Specification* - Section 3.1
 - [CLO-022] - IHE – Cross-Enterprise Document Sharing (XDS.b) Integration Profile as a Document Source Actor with the additional constraints specified in:
 - IS0102 *Saudi eHealth Document Sharing Interoperability Specification* – Section 3.2

- [CLO-023] - IHE Audit Trail and Node Authentication (ATNA) Integration Profile as a Secure Node Actor with the additional constraints specified in:
 - IS0101 *Saudi eHealth Security and Privacy Interoperability Specification* – Section 3.2
- [CLO-024] – IHE Consistent Time (CT) Integration Profile as a Time Client Actor with the additional constraints specified in:
 - IS0101 *Saudi eHealth Security and Privacy Interoperability Specification* – Section 3.1.2

5.3 DOCUMENT REPOSITORY CONFORMANCE

Systems may claim conformance to IS0004 *Saudi eHealth Core Interoperability Specification for Coded Laboratory Orders* as a Document Repository as follows:

“Sharing a Coded Laboratory Order document as a Document Repository Actor”

This requires:

- To support the Publish Document(s) Service by conforming to:
 - [CLO-025]- IHE – Cross-Enterprise Document Sharing (XDS.b) Integration Profile as an Document Repository Actor with the additional constraints specified in:
 - IS0102 *Saudi eHealth Document Sharing Interoperability Specification* – Section 3.4
 - [CLO-026] - IHE Audit Trail and Node Authentication (ATNA) Integration Profile as a Secure Node Actor with the additional constraints specified in:
 - IS0101 *Saudi eHealth Security and Privacy Interoperability Specification* – Section 3.2 and 3.3.1
 - [CLO-027] – IHE Consistent Time (CT) Integration Profile as a Time Client Actor with the additional constraints specified in:
 - IS0101 *Saudi eHealth Security and Privacy Interoperability Specification* – Section 3.1.2
- To support the Query/Retrieve Document(s) Service by conforming to:
 - [CLO-028]- IHE – Cross-Enterprise Document Sharing (XDS.b) Integration Profile as a Document Registry and Document Repository Actor with the additional constraints specified in:
 - IS0102 *Saudi eHealth Document Sharing Interoperability Specification*– Section 3.4
 - [CLO-029] - IHE – Cross-Enterprise User Assertion (XUA) Integration Profile as a X-Service Provider Actor with the additional constraints specified in:

- IS0101 *Saudi eHealth Security and Privacy Interoperability Specification* – Section 3.4.2
- [CLO-030] - IHE Audit Trail and Node Authentication (ATNA) Integration Profile as a Secure Node Actor with the additional constraints specified in:
 - IS0101 *Saudi eHealth Security and Privacy Interoperability Specification* – Section 3.2 and 3.3.1
- [CLO-031] – IHE Consistent Time (CT) Integration Profile as a Time Client Actor with the additional constraints specified in:
 - IS0101 *Saudi eHealth Security and Privacy Interoperability Specification* – Section 3.1.2
- To support the Notification of Document Availability Service by conforming to::
 - [CLO-032] – IHE - Document Metadata Subscription (DSUB) Integration Profile as a Document Metadata Notification Broker Actor with the additional constraints specified in:
 - IS0102 *Saudi eHealth Document Sharing Interoperability Specification* – Section 4.1
 - [CLO-033] - IHE Audit Trail and Node Authentication (ATNA) Integration Profile as a Secure Node Actor with the additional constraints specified in:
 - IS0101 *Saudi eHealth Security and Privacy Interoperability Specification* – Section 3.2 and 3.3.1
 - [CLO-034] – IHE Consistent Time (CT) Integration Profile as a Time Client Actor with the additional constraints specified in:
 - IS0101 *Saudi eHealth Security and Privacy Interoperability Specification* – Section 3.1.2

6. SAUDI EHEALTH CONSTRAINTS ON THE SHARING OF LABORATORY INFORMATION

This section defines required behavior rules for Use Case Actors defined in this Core Interoperability Specification.

The XDS Metadata associated with a Laboratory Order document is defined by two parts: non-laboratory specific XDS Metadata and laboratory specific XDS Metadata.

- [CLO-040] - The non-laboratory specific metadata **SHALL** conform to the requirements specified in the IS0102 *Saudi eHealth Document Sharing Interoperability Specification*-Section 3.2.1.

6.1 REQUIREMENTS FOR LABORATORY ORDER CREATOR

The following rules shall be supported for the conformance to the Laboratory Order Creator Actor:

- [CLO-050] - The Laboratory Order Creator **SHALL** support the creation of Shared Laboratory Orders in the “new” State. The XDS Metadata shall include the following attributes:
 - [CLO-051] An eventCodeList Attribute **SHALL** be created and contain the Order Status code with the value “new”..
 - [CLO-052] An eventCodeList Attribute **SHALL** be created and contain the “Laboratory Specialty code” with one of the coded value defined in the “KSA Laboratory Departments” value set..
 - [CLO-069] A Document Title Attribute **SHALL** be created and contain the “Laboratory” display name with one of the "Print name" value defined in the “Laboratory Departments” value set.
 - [CLO-053] The classCode Attribute **SHALL** contain the “PRESCRIPTIONS” coded value defined in the “KSA Class Code” value set.
 - [CLO-054] The practiceSetting Attribute **SHALL** contain the “practiceSetting” coded value with a value of “Laboratory” as defined in the “Organizational Specialties” value set .
 - [CLO-055] The referenceIdList Attribute (See IHE ITI TF-3 Section 4.2.3.2.28) **SHALL** contain the KSA-Wide Placer Order Number value issued by the Laboratory Order Creator. The structure of this KSA-Wide Placer Order Number is specified in the IS0105 *Saudi eHealth Laboratory Results and Orders Content Interoperability Specification* – See Section 3.1.1.5
 - [CLO-056] The typeCode Attribute **SHALL** contain one coded value for the Requested Laboratory Test Code which is identical to the type code of the Laboratory Order document. The coded values are defined by the “KSA Laboratory Orders and Results” value set. .
 - [CLO-063] The mimeType attribute shall contain one coded value which shall be “text/xml” as described in the “MIME Type” value set .
 - [CLO-064] The formatCode attribute shall contain one coded value which shall be “urn:ksa-ehealth:lab:order:2013” as described in the “KSA Format Code” value set.

- [CLO-058] All other XDS Metadata Attributes **SHALL** contain values as specified in the IS0102 *Saudi eHealth Document Sharing Interoperability Specification*- Section 4.2.1.
- [CLO-059] All other XDS Metadata Attributes with corresponding data elements in the Laboratory Order document **SHALL** be consistent with the values in the Laboratory Order document.
- [CLO-060] – When a Laboratory Order Creator creates a shared Laboratory Orders in the “new” State, the Shared Laboratory Order **SHALL** contain requested laboratory tests for a single laboratory specialty (laboratory department).
- [CLO-061] – When a Laboratory Order Creator creates a Shared Laboratory Order in the “new” State, and specimens have been collected from the patient for the requested laboratory tests at the Laboratory Order Creator facility, the Laboratory Order Creator **SHALL** provide corresponding specimen information within the Shared Laboratory Order document.
- [CLO-065] – The Laboratory Order Creator **SHALL** support the update (replace) of a Shared Laboratory Order (in the “new” State), by replacing the Shared Laboratory Order with an updated Laboratory Order in the “new” State.
 - [CLO-066] – The associated XDS Metadata shall include the attributes specified in [CLO-050] with identical values except for [CLO-056] that **MAY** have been changed.
- [CLO-070] - The Laboratory Order Creator **SHALL** support the update (replace) of a Shared Laboratory Order in the “new” State, by replacing the Shared Laboratory Order with an updated Laboratory Order in the “cancelled” State.
 - [CLO-071] The Laboratory Order Creator **SHALL** include a comment in the Laboratory Order document as to reason why the Shared Laboratory Order has been cancelled.
 - [CLO-072] The associated XDS Metadata **SHALL** include the attributes as specified in [CLO-050] with identical values except for the value of “Order” State in eventCodeList that shall contain the value “CANCELLED”.
- [CLO-075] – If a Laboratory Order has been published and assigned to an incorrect patient, the Laboratory Order Creator **SHALL** correct the error by using the [IHE XDS.b Supplement – Metadata Update: Delete Document Set Request ITI-62] to deprecate the original Order, and a new Order (and associated results, if any) shall be published and assigned to the correct patient. (See IS0102 *Saudi eHealth Document Sharing Interoperability Specification Section 3.2.2* for details).
- [CLO-080] To perform queries, the Laboratory Order Creator [IHE XDS-b: Registry stored Query ITI-18], **SHALL** support the use of the following XDS Metadata Query attributes in Query request:
 - [CLO-081] An eventCodeList that contains the “Order Status” Code. This coded value is defined in the “KSA Order Status” value set.
 - [CLO-083] The documentClass Attribute that contains the “PRESCRIPTIONS” coded value defined in the “KSA Class Code” value set.

- [CLO-084] The “practiceSetting” Attribute **SHALL** contain the “Organizational Specialties” coded value (e.g. Laboratory for lab orders or results) as defined in the “practiceSetting” value set.
 - [CLO-085] The referenceIdList Attribute that contains the “KSA-Wide Placer Order Number” value issued by the Laboratory Order Creator. The structure of this KSA-Wide Placer Order Number is specified in the IS0105 *Saudi eHealth Laboratory Results and Orders Content Interoperability Specification* – See Section 3.1.1.5
- [CLO-086] The typeCode Attribute that contains one coded value for the Requested Laboratory Test. The coded values are defined by the “KSA Laboratory Orders and Results” value set .
 - [CLO-089] Other XDS Metadata Attribute that contain a value as required in the IS0102 *Saudi eHealth Document Sharing Interoperability Specification*-Section 3.2.1 **SHALL** be supported.
- [CLO-090] The Laboratory Order Creator perform Queries [IHE XDS-b: Registry Stored Query ITI-18] it **MAY** support the use of the following XDS Metadata Query attributes in Query request:
 - [CLO-091] An eventCodeList that contains the “Laboratory Specialty” with one of the coded values defined in the “KSA Laboratory Department” value set.
 - [CLO-092] Retired
 - [CLO-093] Other XDS Metadata Attribute **MAY** contain a value as specified in the IS0102 *Saudi eHealth Document Sharing Interoperability Specification*-Section 3.2.1.
- [CLO-095] - The Laboratory Order Creator **MAY** request that a notification be sent to the Lab Order Fulfiller that may be performing the Laboratory Order, to provide an advance notification when the order is created or updated to the “new” State. This notification request is performed by placing the address of the target Laboratory Order Fulfiller in the intendedRecipient XDS Metadata Attribute of the Provide and Register Document Set Transaction– b (IHE ITI-41) used to send the updated order to the Laboratory Repository. The format of the address shall meet the specifications in the IS0102 *Saudi eHealth Document Sharing Interoperability Specification*.

The Lab intendedRecipient can be determined by inspection of the submission set transaction that produced the original order. Additional information on subscriptions can be found in IS0102 *Saudi eHealth Document Sharing Interoperability Specification*- Section 4.

6.2 REQUIREMENTS FOR LABORATORY ORDER FULFILLER

The following rules shall be supported for the conformance to the Laboratory Order Fulfiller Actor:

- [CLO-100] – The Laboratory Order Fulfiller **SHALL** support the update (replace) of orders retrieved in the “new” or “suspended” State by a new Laboratory Order document representing that order is in the “active” State, which means that the

- laboratory has collected/received the appropriate specimen(s) and has the test in-process.
- [CLO-101]The Laboratory Order Fulfiller **SHALL** support the update of the Specimen information (including the Specimen receipt date/time) in the shared Laboratory Order.
 - [CLO-102]The XDS Metadata associated with the updated Laboratory Order document shall include the attributes as specified in [CLO-050] with identical values except for the value of Order State in eventCodeList that shall contain the value “ACTIVE”.
- [CLO-110] – The Laboratory Order Fulfiller **SHALL** support the update (replace) of a Shared Laboratory Order (in the “active” State), by replacing the Shared Laboratory Order with an updated Laboratory Order in the “active” State.
 - [CLO-111]The XDS Metadata associated with the updated order document shall include the attributes as specified in [CLO-050] with identical values except for the value of Order State in eventCodeList that shall contain the value “ACTIVE”.
 - [CLO-115] – The Laboratory Order Fulfiller **SHALL** support the update (replace) of a Shared Laboratory Order (in the “active” State), by replacing the Shared Laboratory Order with an updated Laboratory Order in the “completed” State.
 - [CLO-116] – A Shared Laboratory Order **SHALL NOT** be considered completed until there are no additional requested tests to be performed (the tests have been completed or aborted) and until all of the corresponding shared Laboratory Results Report(s) has/have been stored to the Document Repository
 - [CLO-117] – The XDS Metadata associated with the updated order document shall include the attributes as specified in [CLO-050] with identical values except for the value of Order State in eventCodeList that shall contain the value “COMPLETED”.
 - [CLO-120] – The Laboratory Order Fulfiller **SHALL** support the update (replace) of a Shared Laboratory Order (in the “active” State), by replacing the Shared Laboratory Order with an updated Laboratory Order in the “aborted” State when none of the requested tests have been performed.
 - [CLO-121] – The Laboratory Order Fulfiller **SHALL** include a comment as to reason why the individual tests were aborted in the Laboratory Order document.
 - [CLO-122] – The XDS Metadata associated with the updated order document shall include the attributes as specified in [CLO-050] with identical values except for the value of “Order State” in eventCodeList that shall contain the value “ABORTED”.
 - [CLO-130] – The Laboratory Order Fulfiller **SHALL** support the update (replace) of a Shared Laboratory Order (in the “active” State), by replacing the Shared Laboratory

- Order with an updated Laboratory Order in the “new” State when none of the requested tests have been performed.
- [CLO-131] – A Shared Laboratory Order **SHALL NOT** return an order if any of the requested tests have been performed.
 - [CLO-132] – The Laboratory Order Fulfiller **SHALL** include a comment as to reason why the order was returned, in the Laboratory Order document.
 - [CLO-133] – The XDS Metadata associated with the updated order document shall include the attributes as specified in [CLO-050] with identical values except for the value of Order State in eventCodeList that shall contain the value “NEW”.
- [CLO-140] – The Laboratory Order Fulfiller **SHALL** support the update (replace) of a Shared Laboratory Order (in the “active” State), by replacing the Shared Laboratory Order with an updated Laboratory Order in the “suspend” State.
 - [CLO-141] The XDS Metadata associated with the updated order document shall include the attributes as specified in [CLO-050] with identical values except for the value of “Order State” in eventCodeList that shall contain the value “SUSPEND”.
 - [CLO-142] – The Laboratory Order Fulfiller **SHALL** include a comment as to reason why the order was suspended, in the Laboratory Order document.
 - [CLO-150] – The Laboratory Order Fulfiller **SHALL** support the update (replace) of a Shared Laboratory Order (in the “completed” State), by replacing the Shared Laboratory Order with an updated Laboratory Order in the “completed” State to amend/correct a completed Shared Laboratory Order.
 - [CLO-151] – The XDS Metadata associated with the updated order document shall include the attributes as specified in [CLO-050] with identical values.
 - [CLO-160] – When retrieving a patient’s Laboratory Order, it is the responsibility of the Order Fulfiller to rely on the Metadata associated with the Laboratory Order to reconcile the KSA-Wide information with its local information and conventions. At a minimum, the Order Fulfiller **SHALL** reconcile:
 - The KSA-Wide Health ID with the local Patient ID, if the KSA-Wide Health ID is not used locally.
 - The Saudi eHealth Laboratory Order Codes with the corresponding local Laboratory Order Codes if the KSA Laboratory Orders and Results Codes are not used locally.
 - The KSA-Wide Order Filler ID with a link to a corresponding local Order Filler ID
 - [CLO-170] - The Laboratory Order Fulfiller **SHALL** request that a notification be sent to the Lab Order Creator Actor that issued the order, to indicate an update by the Lab Order Fulfiller Use Case Actor of its Laboratory Order (Lab Order Fulfiller Notification Option) when the order is updated to the “completed”, “aborted” or “suspended” states. This notification request is performed by placing the address of the Laboratory Order Creator Use Case Actor that created the order in the intendedRecipient XDS Metadata Attribute
-

in the Provide and Register Document Set Transaction – b (IHE ITI-41) used to send the updated order to the Laboratory Repository Use Case Actor. The format of the address shall meet the specifications in the IS0102 *Saudi eHealth Document Sharing Interoperability Specification*.

The Lab intendedRecipient can be determined by inspection of the submission set transaction that produced the original order. Additional information on subscriptions can be found in IS0102 *Saudi eHealth Document Sharing Interoperability Specification*-Section 4.

6.3 REQUIREMENTS FOR DOCUMENT REPOSITORY

The following rules shall be supported for the conformance to the Document Repository Actor:

- [CLO-180] – When responding to a query, a Document Registry **SHALL** be able to support the return of several Orders for the same patient.
- [CLO-181] Orders filtering **SHALL** support the use of the “KSA-Wide Placer Order Number” stored in a referenceIdList slot (See IHE ITI TF-3 Section 4.2.3.2.28).
- [CLO-182] – The following stored queries **SHALL** be supported by the XDS Document Registry:
 - FindDocuments
 - FindSubmissionSets
 - GetAll
 - GetDocuments
 - GetAssociations
 - GetDocumentsAndAssociations
 - GetSubmissionSets
 - GetSubmissionSetAndContents
 - GetRelatedDocuments

Folder related transaction **MAY** be optionally supported:

- FindFolders
- GetFolders
- GetFolderAndContents
- GetFoldersForDocument

7. REFERENCED DOCUMENTS AND STANDARDS

The following Saudi eHealth documents are referenced by this Interoperability Specification.

TABLE 7-1 INTERNAL REFERENCES

MOH DOCUMENT	DESCRIPTION
IS0001 Saudi eHealth Core Interoperability Specification for KSA-Wide Patient Demographic Query	Documents the specifications required to obtain patient IDs and demographic information for the patient. It is used to ensure that the nationwide Health ID is used to register laboratory orders for the correct patient.
IS0003 Saudi eHealth Core Interoperability Specification for Sharing Coded Laboratory Results	Describes the technical requirements for the interface to share coded Laboratory Results Reports via the Saudi eHealth Exchange (SeHE). These laboratory test results are generally used by primary and hospital care providers but may also be used by MOH Business Applications, including public health/MOH business organizations. Note that policies may require that patient information be pseudonymized for use in MOH business applications.
IS0101 Saudi eHealth Security and Privacy Interoperability Specification	The Saudi eHealth Security and Privacy Interoperability Specification Specifies the interoperability standards and profiles along with the Saudi specific constraints that are required to provide the technical security measures, data protection, and privacy management that will facilitate the implementation of the Saudi eHealth Policies for Health Information Exchange in the Kingdom of Saudi Arabia among communicating IT systems
IS0102 Saudi eHealth Document Sharing Interoperability Specification	Forms a "container" for set of requirements that complement the IHE XDS Profile with Saudi eHealth specific constraints when it is called upon by any of the Core Interoperability Specifications.
IS0105 Saudi eHealth Laboratory Results and Orders Content Interoperability Specification	Specifies the clinical content for cross-enterprise sharing of laboratory orders Laboratory Orders and results based upon the IHE XD-LAB Content Profile. This interoperability specification focuses on the Saudi eHealth specific constraints.
IS0106 Saudi eHealth Clinical Documents Constrains Interoperability Specifications	Specifies common constraints for clinical documents such as data elements of document headers that are common across the Saudi eHealth Project.
IS0200 Saudi eHealth Terminology Repository	Specifies the terminology concepts and associated coded value sets for data elements used throughout the Saudi eHealth Interoperability Specifications.
UC0003 Saudi eHealth Laboratory Interoperability Use Case	Provides the ability to share laboratory test results and to initiate a coded laboratory order, and making them accessible via the SeHE platform.
Saudi Health Information Exchange Policies	The Saudi Health Information Exchange Policies apply Applies to all individuals and organizations that have access to the Saudi Health Information Exchange managed health records, including those connected to the Saudi Health Information Exchange, their Business Associates, as well as any subcontractors of Business Associates. These policies apply to all information provided to or retrieved from the Saudi Health Information Exchange.

TABLE 7-2 EXTERNAL REFERENCES

STANDARD	DESCRIPTION
Health Level Seven (HL7) Clinical Document Architecture Release 2 (CDA R2)	<p>The HL7 Clinical Document Architecture (CDA) Release 2 is an XML-based document markup standard that specifies the structure and semantics of clinical documents for the purpose of exchange. CDA R2 further builds upon the Version 3.0 Reference Information Model (RIM) Standard.</p> <p>For more information See http://www.hl7.org/implement/standards/product_brief.cfm?product_id=7</p>
IHE IT Infrastructure (ITI) Technical Framework – Volume 1 (ITI TF-1) Integrations Profiles, Section 10 Cross-Enterprise Document Sharing (XDS.b)	<p>The Cross-Enterprise Document Sharing (XDS.b) IHE Integration Profile facilitates the registration, distribution and access across health enterprises of patient electronic health records. This profile is focused on providing a standards-based specification for managing the sharing of documents between healthcare enterprises, ranging from a private physician office to a clinic to an acute care in-patient facility.</p> <p>May be obtained at http://www.ihe.net/Technical_Frameworks/#iti</p>
IHE IT Infrastructure (ITI) Technical Framework – Volume 1 (ITI TF - 1) Integration Profiles,–Final Text Supplement -- XDS Metadata Update	<p>This supplement updates the XDS and XDR profiles to add support for the updating and deleting of metadata.</p> <p>One new actor and two new transactions are introduced. The Document Administrator actor is the source of the new transactions. The Update Document Set transaction carries metadata updates and the Delete Document Set transaction enables metadata deletion. These new capabilities are assigned to a new actor and new transactions to enable tighter authentication/authorization control over their use. May be obtained at http://www.ihe.net/Technical_Frameworks/#iti</p>
IHE IT Infrastructure (ITI) Technical Framework – Volume 3 (ITI TF-3) Integrations Profiles, Section 4 Metadata used in Document Sharing profiles	<p>Describes the metadata that is used in IHE profiles designed for sharing documents (Document Sharing profiles). The Document Sharing profiles are implementing the Document</p> <p>Sharing concept outlined in the ITI whitepaper entitled Health Information Exchange: Enabling Document Sharing Using IHE Profiles</p> <p>May be obtained at http://www.ihe.net/Technical_Frameworks/#iti</p>
IHE Laboratory Technical Framework Volume 3 (LABTF-3) Content	<p>This Content Integration Profile describes a clinical laboratory report as an electronic document to be published towards a document sharing resource such as an Electronic Health Record (EHR) or a Personal Health Record (PHR) shared by a community of care providers, using one of the document sharing profiles defined in ITI-TF. Such an electronic document contains the set of releasable results produced by a clinical laboratory in fulfillment of one or more test Orders for a patient. The report is both human-readable and importable in the consumer systems so as to consolidate their patient medical records.</p> <p>The scope of this profile covers all laboratory specialties except anatomic pathology. May be obtained at http://www.ihe.net/Technical_Frameworks/#laboratory</p>

8. APPENDIX B – EXAMPLE MESSAGES/DOCUMENTS

EXAMPLES WILL BE PROVIDED AS PART OF THE IS SPECIFICATION VALIDATION PROCESS. UNTIL THEN THIS SECTION WILL REMAIN BLANK.